

**NEW**

3DX | BACKHOE LOADER



## 3DX Backhoe Loader

4WD Gross Engine Power 92hp (68kW) Standard GP Shovel Capacity 1.1 cum Travel speed – 40kph (25mph)

4WD Gross Engine Power 76hp (56kW) Standard GP Shovel Capacity 1.1 cum Travel speed – 36kph (22mph)





# THE WORLD'S NUMBER ONE.

JCB PIONEERED THE BACKHOE LOADER IN 1953. SINCE THEN, WE'VE REMAINED THE MARKET LEADER, INVENTING FEATURES LIKE 4WD AND THE SIDE-SHIFT CHASSIS. AS YOU'D EXPECT, THE NEW 3DX CONTINUES THIS TRADITION, DELIVERING CLASS-LEADING PRODUCTIVITY, COMFORT AND FUEL SAVINGS.



1

## Ultimate versatility.

**1** As the market leader, JCB sells around half of all the world's backhoe loaders.

**2** A JCB backhoe is the most versatile construction machine you can buy. Combining the key benefits of both loading shovels and excavators, it's effectively two machines in one package.

**3** A JCB backhoe is designed to drive around sites, drive between sites, and then drive home at the end of the day.



2



3

# BUILT TO LAST.

THE NEW JCB 3DX IS THOROUGHLY STRESS TESTED AND CLIMATE TESTED. IT'S ALSO BUILT USING ONLY THE FINEST COMPONENTS, WHICH ENSURES THAT IT'S DURABLE ENOUGH TO CARRY OUT THE HARDEST TASKS.

## Ultimate performance.

1 The new JCB 3DX uses JCB's own special backhoe loader driveline. This is a popular, trusted, well-proven unit that works in perfect harmony with our machines for ultimate uncompromised performance.

2 Because the JCB 3DX is used by customers all over the world, we've tested it rigorously in climates ranging from -20°C to 50°C. Its JCB DIESELMAX engine has excellent fuel filtration to handle varying fuel quality.

3 We've stress tested the new 3DX across 1.2 million cycles of the hardest digging and loading applications. As a result, every part of the machine can perform the very toughest duties.

4 We check every 3DX cab for leaks so you can be sure of a dry, dust free cab.

The excavator end is heavily reinforced with thick steel, and there are replaceable wear plates on the bucket and dipper to protect from hard material like rock.



To protect the 3DX from damage, we've fitted steel fenders, bonnet and nose.





## PRODUCTIVITY AND PERFORMANCE: EXCAVATOR.

**POWERFUL HYDRAULICS, HUGE TEAROUT FORCES, COMMANDING VISIBILITY AND PERFECTLY MATCHED COMPONENTRY, THE NEW JCB 3DX'S EXCAVATOR ARM IS DESIGNED TO PROVIDE UNSURPASSED PRODUCTIVITY, SPEED AND CONTROL.**

### **Excavating performance.**

- 1** We use a high pressure efficient hydraulic system with large hydraulic cylinders. This provides the 3DX with big tearout forces – perfect for hard ground and arduous digging.
- 2** With a 5700 kgf bucket tearout, the new 3DX is supremely productive, even in the hardest applications.
- 3** The boom and dipper are perfectly matched, meaning you can dig right up to the bottom of the boom reducing repositioning of the machine and providing better visibility.
- 4** A 128-litre fuel tank allows all-day working without refuelling.



The JCB 3DX has a narrow-profile boom and dipper for superb visibility when excavating.





## PRODUCTIVITY AND PERFORMANCE: LOADER.

THE FRONT END OF THE NEW JCB 3DX DELIVERS UNSURPASSED PRODUCTIVITY, SPEED AND CONTROL, COURTESY OF A HEAVY-DUTY LOADER ARM, SELF LEVELLING GEOMETRY AND GREAT VISIBILITY. ALSO UP FRONT IS OUR INNOVATIVE HIGH TORQUE JCB DIESELMAX ENGINE.

### Loading performance.

- 1 JCB's cutting edge DIESELMAX engine was designed from scratch to produce superb performance, high torque levels and ultimate productivity.
- 2 With tens of thousands of units in service around the world, carrying out many applications, the DIESELMAX engine is renowned for its reliability.
- 3 4-ram parallel lift loader geometry means clear visibility, excellent load retention, superb dump height, long reach, and fast truck loading.
- 4 To make visibility even better, the new 3DX has a sloping bonnet line, which provides an unhindered view of the shovel for loading and site clearance.
- 5 A D-shaped, durable, heavy-duty design means the 3DX's loader arms don't twist or flex. As a result, there's a formidable shovel breakout of 6500 kgf, as well as excellent lift capacity.





## COST OF OWNERSHIP.

JCB'S LEGENDARY BUILD QUALITY AND GLOBAL BRAND HELP KEEP CUSTOMER DEMAND AND MACHINE RESIDUALS HIGH. AND THE BENEFITS OF OWNING A NEW JCB 3DX DON'T STOP THERE.



The 3DX's JCB DIESELMAX engine delivers excellent fuel efficiency.



### Saving money.

- 1** We understand that fuel is one of a backhoe loader's biggest costs. That's why we've designed the new 3DX to provide a combination of increased productivity and reduced fuel consumption, saving you money.
- 2** We've used only proven, reliable components on the new JCB 3DX to maximise uptime and ensure that your machine spends as much time as possible earning you money.
- 3** By extending service intervals for fluids and filters, we've brought down cost of ownership even more.



## EASE OF MAINTENANCE.

OUR MACHINES MAY BE EXTREMELY DURABLE BUT EVEN A JCB NEEDS ROUTINE MAINTENANCE. HOWEVER WE'VE DESIGNED THE NEW 3DX TO BE EASILY SERVICEABLE, BOTH TO MAXIMISE UPTIME AND TO MAKE LIFE EASIER.

### Routine maintenance.

**1** A full opening gas-assisted bonnet provides easy engine access, and you can open it up with just one lever.

Every daily check can be done at ground level from one side of the machine.

**2** The new 3DX's loader arm mounting pivots and excavator end are machined so they always align correctly. Meanwhile, our specially designed brass bushes provide a long wear-free life.

**3** To protect the engine and optimise performance on the new 3DX, we've fitted large fuel pre-filters and a water separator; this setup helps keep contaminants out of the fuel system. We also have an air filter which is regularly cleaned by the engines own exhaust system.

**4** Hydraulic oil level is clearly shown via a side mounted site gauge. You can fill the hydraulic and diesel tanks easily at ground level.

	SERVICE INTERVALS
Engine oil	Every <b>500</b> hours
Engine oil filter	Every <b>500</b> hours
Hydraulic filter	Every <b>500</b> hours
Hydraulic oil	Every <b>2000</b> hours
Transmission filter	Every <b>500</b> hours
Transmission oil	Every <b>500</b> hours
Axle oil	Every <b>1000</b> hours





## THE PERFECT PLACE TO WORK.

A COMFORTABLE OPERATOR IS A PRODUCTIVE OPERATOR. WITH THAT IN MIND, WE'VE DESIGNED THE NEW JCB 3DX TO INCORPORATE HIGH COMFORT LEVELS INTO ITS ERGONOMIC WORKING ENVIRONMENT.



2

### Comfortable operation.

1 The 3DX's cab is large and easy to access, with plenty of leg room in every operating position.

The new 3DX has ergonomically-placed controls and a comfy seat. The result? A comfortable, alert, productive operator.

2 The braking system provides high performance with minimum effort for fatigue free operation and excellent control.

3 A high-power face fan increases comfort in hot environments.

The new 3DX is well-ventilated via partial or full opening on both front and rear side windows.

4 We've made the electrical system dust-and-waterproof for trouble-free long-life performance.

5 Our dedicated in-cab storage is safe and convenient.



1



3



4



5



## JCB SUPPORT.

JCB IS NO ORDINARY COMPANY. FROM THE DREAMS OF ONE MAN, WE HAVE GROWN INTO THE WORLD'S LARGEST PRIVATELY OWNED COMPANY BY VOLUME. WE AIM FOR 100% SATISFACTION – IT'S ALL PART OF OUR PROMISE TO PUT YOU, THE CUSTOMER, FIRST.



1 JCB is one of the top three manufacturers of construction equipment with 22 manufacturing facilities across the world. Our Headquarters based in the UK is home to the world's best-selling backhoe loader and the world's best-selling telescopic handler.

2 Customers are at the heart of everything we do. Whatever a customer needs, we make it our mission to provide 100% satisfaction. Our 750 dealers, operating from 2000 locations, in 150 countries around the world are focused on putting customer needs first.

3 The global network of JCB Parts Centres is another model of efficiency; with 15 regional bases, we can deliver around 95% of all parts anywhere in the world within 24 hours. Our genuine JCB parts are designed to work in perfect harmony with your machine for optimum performance and productivity.

Sir Anthony Bamford, the son of Mr JCB still runs the company today.



STATIC DIMENSIONS

Loader end max. payload: 1850kg (4078lb) Max. lift height: 3.23metres (10.59ft)

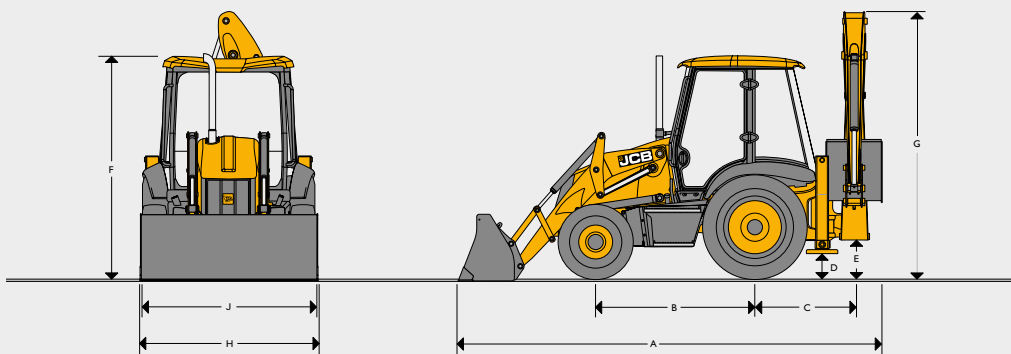

3DX / 3DX Plus		
A	Total travel length	m 5.96
B	Wheelbase	m 2.24
C	Slew centre to rear axle centre	m 1.32
D	Minimum ground clearance (stabiliser foot clearance)	m 0.36
E	Slew ground clearance	m 0.53
F	Cab roof height	m 2.87
G	Total travel clearance	m 3.61
H	Shovel width	m 2.23 (6-in-1 shovel) / 2.35 (GP shovel)
J	Rear frame width	m 2.24

ENGINE

	3DX	3DX Plus
Model	JCB 448, 4 cylinder, water cooled, diesel	JCB 444, turbocharged, 4 cylinder, water cooled, diesel
No. of cylinders	4	4
Displacement	4.8 litres	4.4 litres
Gross power	56kW (76 hp) @ 2200rpm	68.6 kW (92hp) @ 2200rpm
Max torque	301Nm (31.6 kgm) @ 1200rpm	408Nm (41.6 kgm) @ 1200rpm

SERVICE CAPACITIES

Cooling system	ltr	16.5
Fuel tank	ltr	128
Engine oil with filter	ltr	14
Gearbox with filter	ltr	16
Rear axle	ltr	21
Front axle	ltr	11
Hydraulic system incl. tank	ltr	130

EXCAVATOR/LOADER PERFORMANCE

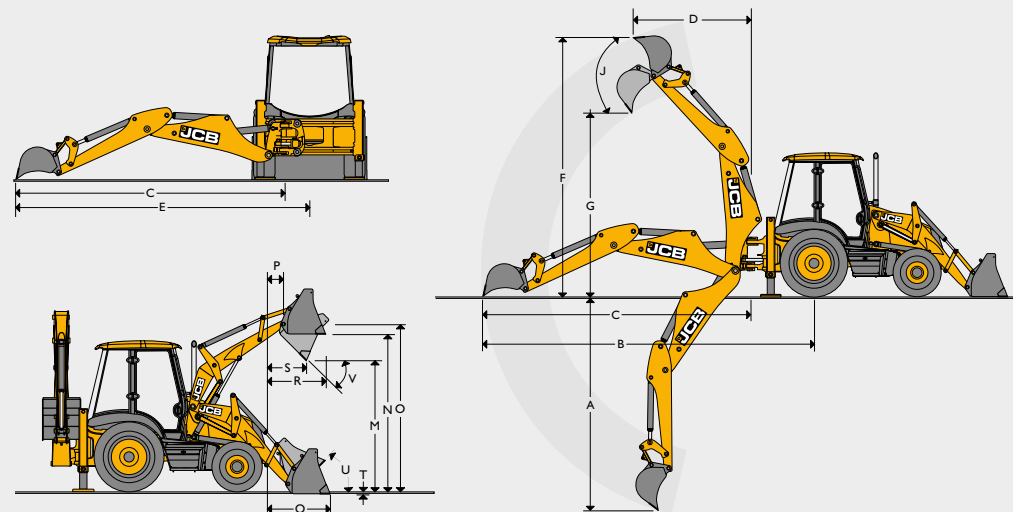

Excavator performance		3DX / 3DX Plus
A	Max dig depth	m 4.77
B	Reach-ground level to rear wheel centre	m 6.72
C	Reach-ground level to slew centre	m 5.40
D	Reach at full height to slew centre	m 2.74
E	Side reach to centre line of machine	m 6.02
F	Max. working height	m 5.97
G	Max. load over height	m 4.18
H	King post travel	m 1.06
J	Bucket rotation – power	degrees 185°
	Bucket tearout force	kgf 5700
	Dipper tearout force	kgf 3010
	Lift capacity to bucket pivot	kg 1490
Loader performance		
M	Dump height	m 2.72
N	Load over height	m 3.23
O	Pin height	m 3.45
P	Pin forward reach	m 0.36
Q	Reach at ground	m 1.40
R	Max. reach at full height	m 1.15
S	Reach at full height – bucket dumped	m 0.78
T	Below ground level dig depth	m 0.10
U	Rollback at ground	degrees 45°
V	Dump angle	degrees 43°
	Shovel breakout force	kgf 6500
	Loader arm breakout force	kgf 4850
	Shovel capacity	1.0m <sup>3</sup> (6-in-1 shovel) / 1.1m <sup>3</sup> (GP shovel)



## TRANSMISSION

JCB Synchro-shuttle transmission: It provides superb drive power in all conditions. It consists of a 4-speed, full synchromesh gearbox with integral torque convertor and electrically operated reversing power shuttle.

- Easy-to-use, column mounted electric reversing shuttle which can change machine direction while allowing operator to keep hands on the steering wheel leading to fast cycle times.
- The pedal layout and conventional 4-pattern gear lever with transmission disconnect switch adds to the overall ease of operation. On-the-move gear changes are possible.
- Torque convertor stall ratio is 2.52:1 (4WD)

	3DX (4WD)
Manufacturer	JCB
Type	Synchroshuttle
Gears forward/reverse	4 forward/2 reverse
Shuttle control – F/R	Power shuttle
<b>Travel speeds*</b>	<b>kph</b>
Gear 1	7.3
Gear 2	11.7
Gear 3	22.0
Gear 4	40.0

\*Speeds may vary dependant on tyre selection.

## TURNING CIRCLE

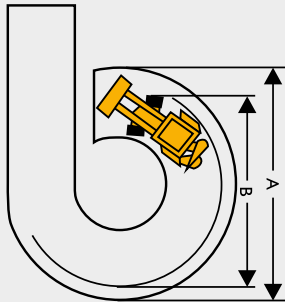

### Inner wheels braked

A Outside loader bucket	9.79m
B Outside wheels	7.21m
<b>Inner wheels not braked</b>	
A Outside loader bucket	10.91m
B Outside wheels	8.32m

\* Standard bucket in travel position

## STEERING

Front wheel full power hydrostatic system utilising the main hydraulic pump via a steering priority valve. In the event of engine failure, emergency steering is maintained (all models).

## BRAKES

**Service:** Hydraulically actuated dual line, self adjusting, oil immersed, multi-disc type on the rear axle, well protected from dirt, water etc. requiring no maintenance.

**Parking:** Hand operated, disc brake on rear axle input disc.

**Brake pedal:** Two independently operable foot pedals enable machine to manoeuvre in tight spaces. Pedals are linked together for normal use.

**2WD / 4WD:** Electrical selection between 2WD / 4WD allows on-the-move changes.

## HYDRAULIC SYSTEM

• JCB vari-matic hydraulics • Main relief valve: 228bar • Unloader valve: 207bar • Pump type: 2 section displacement gear • Pump capacity: 3DX: 108 lpm, 3DX Plus: 123 lpm • Filtration through suction strainer and return line JCB Filtermatic filter • During excavation the circuit automatically varies hydraulic power to match digging conditions for extra performance, control and power • Careful routing of hydraulic hoses and pipework guards against site damage and allows easy servicing

## CAB

• Floormats • Fully adjustable seat and soft touch steering wheel • 'Walk through' two door access • Seat belt, large convex rear view mirror, interior light front screen wiper, horn, hazard warning system, tool box • Instrumentation panel includes engine speed, engine hours, fuel level, water temperature gauge and 12v connection • Audible and visual fault warning system for alternator charge, coolant temperature, engine oil pressure, blocked air filter, transmission oil pressure and temperature, and hand brake on.

## AXLES

**Rear:** Drive axle rigidly mounted, incorporates JCB Max-Trac torque proportioning differential, driven by short propshaft from gear box.

**Front:** 4WD, Steer axle, centrally pivoted with oscillation angle of 16°.

## ELECTRICAL AND INSTRUMENTATION

12 volt negative ground, utilising wiring and connectors meeting IP69 water ingress test standard. Central fuse panel.

**Battery:** 130 A/hr **Alternator:** 90 amp standard. **Front working lights:** 2 fixed.

**Rear working lights:** 2 fixed and 2 adjustable.

## TYRES

**Front:** 12.5x18-12PR (4WD)

**Rear:** 16.9x28-12PR (4WD)

## WEIGHT

**Shipping:** 3DX/3DX Plus: 7660kg

**Operating:** 3DX/3DX Plus: 7800kg

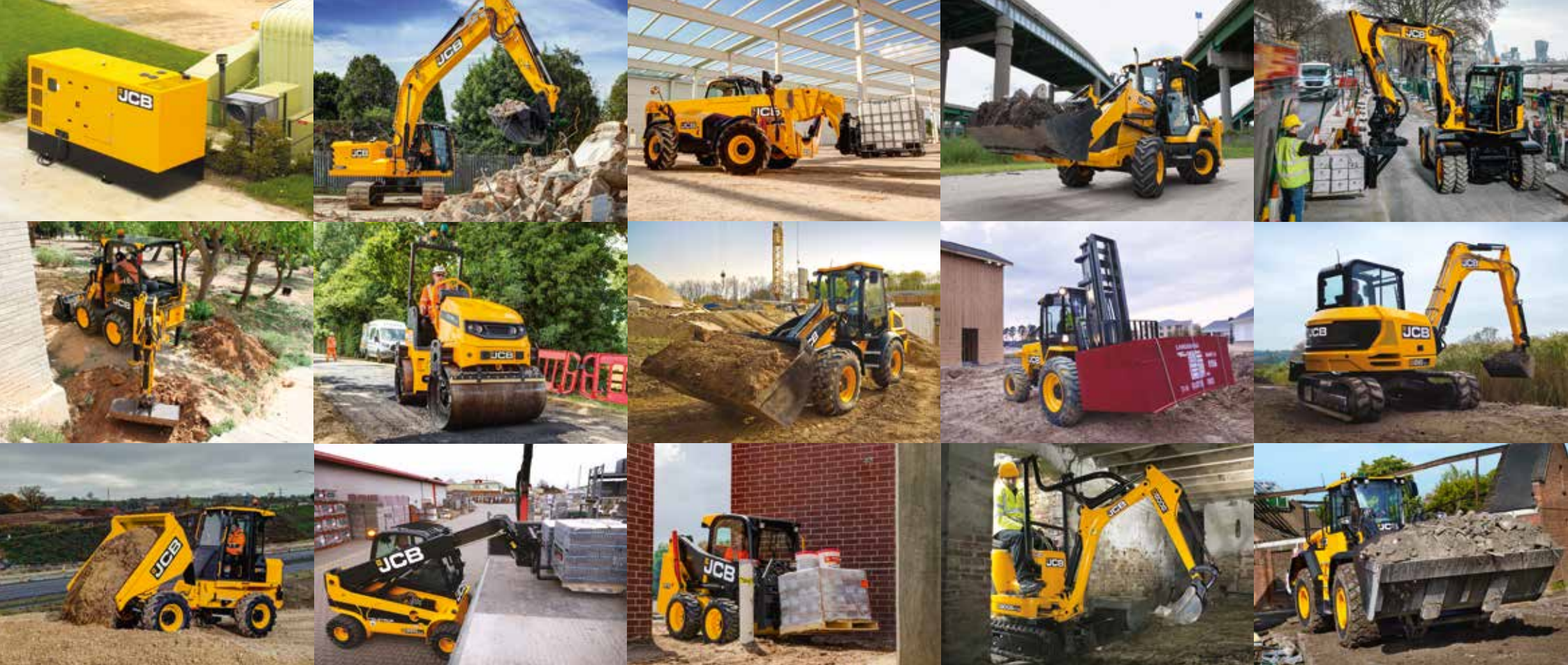

**ONE COMPANY, OVER 300 MACHINES.**

**BACKHOE LOADER 3DX**

3DX	Gross Engine Power 76hp (56kW) Standard GP Shovel Capacity 1.1m <sup>3</sup> Travel speed – 36kph (23mph)
3DX PLUS	Gross Engine Power 92hp Standard GP Shovel Capacity 1.1m <sup>3</sup> Travel speed – 40kph (25mph)

