

---

[pktrucks.com](http://pktrucks.com)

Technical sheet :

# MT-X 1840 A

---



 **MANITOU**  
HANDLING YOUR WORLD

Capacities		Metric
Max. capacity		4000 kg
Max. lifting height		17.55 m
Max. outreach		9.60 m
Breakout force with bucket		8400 daN
Weight and dimensions		
Overall length to carriage	l11	6.16 m
Length to face of forks	l2	6.27 m
Overall width	b1	2.42 m
Overall height	h17	2.45 m
Wheelbase	y	3.07 m
Ground clearance	m4	0.37 m
Overall cab width	b4	0.89 m
Tilt-up angle	a4	12 °
Tilt-down angle	a5	114 °
External turning radius (over tyres)	Wa1	3.94 m
Overall weight		12560 kg
Unladen weight (with man basket)		12560 kg
Tires type		Pneumatic
Standard tires		Alliance 400/80 - 24 - 162A8
Forks length / width / section	l / e / s	1200 mm x 125 mm x 50 mm
Performances		
Lifting		18 s
Lowering		14.40 s
Extension		17.90 s
Retraction		16.50 s
Crowd		5.10 s
Dump		4 s
Engine		
Engine brand		Perkins
Engine norm		Stage IIIA
Max. fuel sulphur content		5000 ppm
Engine model		1104D-44TA
Number of cylinders / Capacity of cylinders		4 - 4400 cm <sup>3</sup>
I.C. Engine power rating - Power		101 Hp / 74.50 kW
Max. torque / Engine rotation		400 Nm @ 1400 rpm
Drawbar pull (Laden)		10000 daN
Transmission		
Transmission type		Torque converter
Number of gears (forward / reverse)		4 / 4
Max. travel speed		24.90 km/h
Parking brake		Automatic Negative Hand-brake
Service brake		Oil-immersed multi-discs braking on front & rear axles
Hydraulics		
Hydraulic pump type		Gear pump
Hydraulic flow / Pressure		167 l/min-265 bar
Tank capacities		
Engine oil		11.40 l
Hydraulic oil		135 l
Fuel tank		140 l
Noise and vibration		
Noise at driving position (LpA)		82 dB
Noise to environment (LwA)		105 dB
Vibration on hands/arms		< 2.50 m/s <sup>2</sup>
Compatible platform		
Platform capacity	Q	1000 kg
Number of people		3
Platform dimensions (length x width)	lp / ep	5000 m x 1200 m
Platform weight*		1150 kg
Miscellaneous		
Steering wheels (front / rear)		2 / 2
Drive wheels (front / rear)		2 / 2
Safety cab homologation		Cabin ROPS - FOPS level 2
Controls		JSM

MT-X 1840 A - Dimensional drawing



MT-X 1840 A - Load chart

Machine on tyres with forks - with levelling device Metric

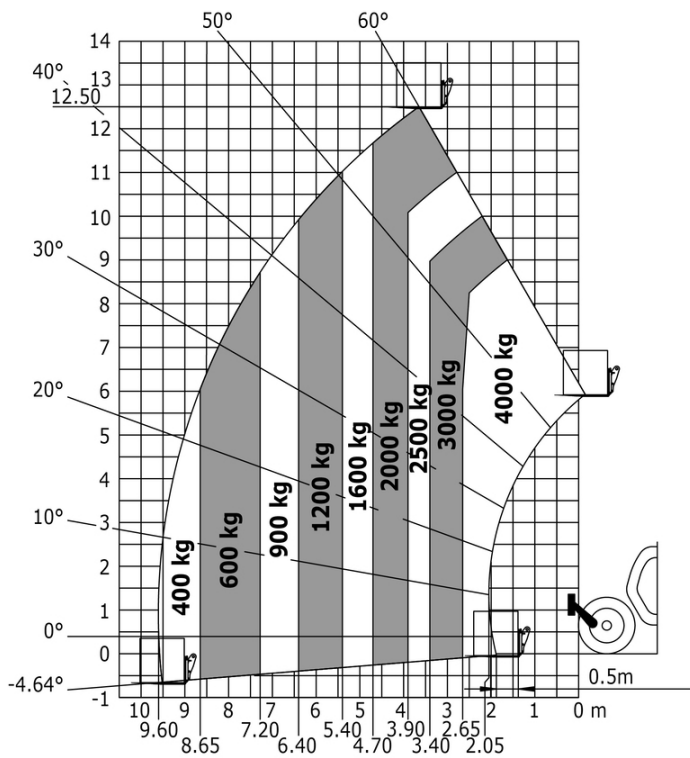

Machine on lowered stabilisers with forks Metric

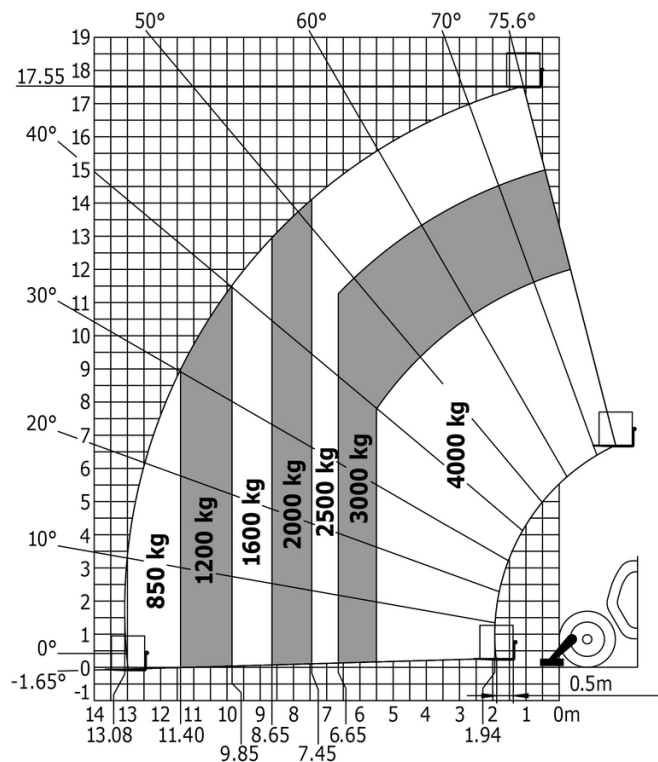

Machine on stabilisers with Man basket Metric

