



DUCATO SAFETY 2 - MY 2024

NEW COLORS, NEW EQUIPMENT, NEW MATERIALS THAT DISTINGUISH THE LATEST EVOLUTION OF THE BEST-SELLING OLMEDO AMBULANCE ON THE MARKET

BORN TO CARE, EVOLVED TO PROTECT

Essential, rational, robust: these are the distinguishing features of **Safety II**, which comes in this completely new "model year" even more evolved than the already highly appreciated previous versions. This is the ambulance built on a Ducato base that is most popular in the market, combining in a single product all Olmedo's features and quality at an attractive price; this is thanks to the continuous and tireless efforts to refine and select ultralight materials, eliminating what is unnecessary. The result of this research is a concentrate of technology that does not contain unnecessary elements; **Safety II** features the systems, panelling, flooring, upholstery and homologation compliances typical of the "sisters" in Olmedo's "Ambulance Division" range. **Safety II** includes a wide range of accessory equipment to customize its use to the Customer's habits, while not forgetting the 3 founding elements of the special vehicle industry: **essentiality, rationality, robustness.**



MY 2024: THE BEST SAFETY EVER

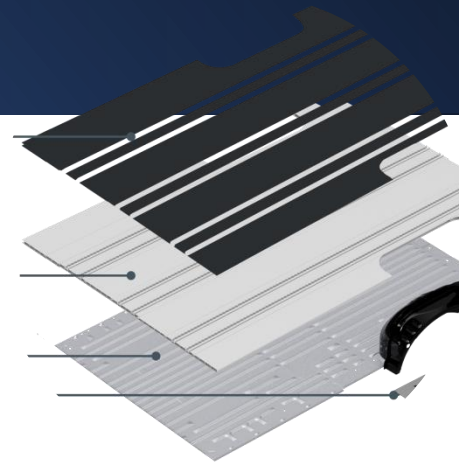

- NEW "AVIO" FLOORING IN ULTRA-RESISTANT ALUMINIUM ALLOY, WHICH MAKES IT POSSIBLE AN OVERALL WEIGHT REDUCTION OF OVER 70 KG COMPARED TO TRADITIONAL WOOD FLOORING WITH REINFORCED STEEL PLATES.
- NEW PANNELLING AND STRUCTURAL COMPONENTS IN ULTRA-LIGHT ALUMINIUM
- NEW FEET FOR FIXING SEATS, WITHOUT THROUGH HOLES AND ULTRALIGHT
- NEW **UPHOLSTERY COLORS**, WITH ULTRA BRIGHT AND ULTRA RESISTANT «**PROFESSIONAL SILVER**» SHADES
- NEW 10" TOUCH-SCREEN PANELS AND INTEGRATED X-LINK SYSTEM, WHICH CAN ALSO BE SET UP IN AFTER-SALES SERVICE

MY 2024: THE BEST SAFETY EVER



- NEW ULTRA-LIGHT AVIATION GRADE ALUMINIUM «**AVIO RACK**» FOR CUSTOMIZED POSITIONING OF ELECTROMEDICAL EQUIPMENT
- NEW **COLOURS FOR THE INTERIORS**, WITH ULTRA BRIGHT AND ULTRA RESISTANT "PROFESSIONAL SILVER" SHADES
- NEW **AIR SANITATION SYSTEMS** USING UV-C AND PHOTOCATALYSIS, INTEGRATED IN THE REAR AIR CONDITIONING SYSTEM
- NEW **ENVIRONMENTAL STANDARDS**, DEVELOPED FOR THE INTRODUCTION OF THE **NEGATIVE PRESSURE SYSTEM** (PATENTED) WITH SOFTWARE FOR READING THE AIR QUALITY

NEW REFERENCE STANDARDS

LESS WEIGHT

```
graph TD; A[LESS WEIGHT] --> B[REDUCED CONSUMPTION]; B --> C[LESS POLLUTION]; C --> D[GREATER SAFETY];
```

REDUCED
CONSUMPTION

LESS POLLUTION

GREATER SAFETY





NEW BASIC SPOILER

- AERODYNAMIC FRONTAL DESIGN WITH STRUCTURE SHAPED TO THE VEHICLE
- LOW PROFILE TO REDUCE OVERALL HEIGHT
- "SPECIAL" LIGHT POINTS FOR VEHICLE LOCATION BY AIRCRAFTS
- INTEGRATED REAR LIGHT SPOTLIGHTS WITH ENHANCED EMISSION
- LED SWINGING BEACON INTEGRATED WITH THE SPOILER STRUCTURE





AESTHETICS AND STYLE

- EYE-CATCHING AESTHETICS AND AERODYNAMICS WITH STYLE-INTEGRATED EQUIPMENT
- FRONT ACOUSTIC SYSTEMS THAT INCREASE SOUND AND MAKE MAINTENANCE EASIER (CAN ALSO BE INSTALLED ON THE SPOILER)

A COMPLETE RANGE

The **DUCATO** range now features ideal configurations and engines to meet all the needs of customers specialised in rescue services. **Safety II** conversion is already compliant with all the versions currently on the FIAT price list, granting uniformity with the solutions offered by the parent company and approved to ensure coverage under the original warranties. The **EURO 6D-FINAL engines from 120 to 180 HP** make Ducato one of the most versatile vehicles for ambulance use and with maximum attention to environmental protection.



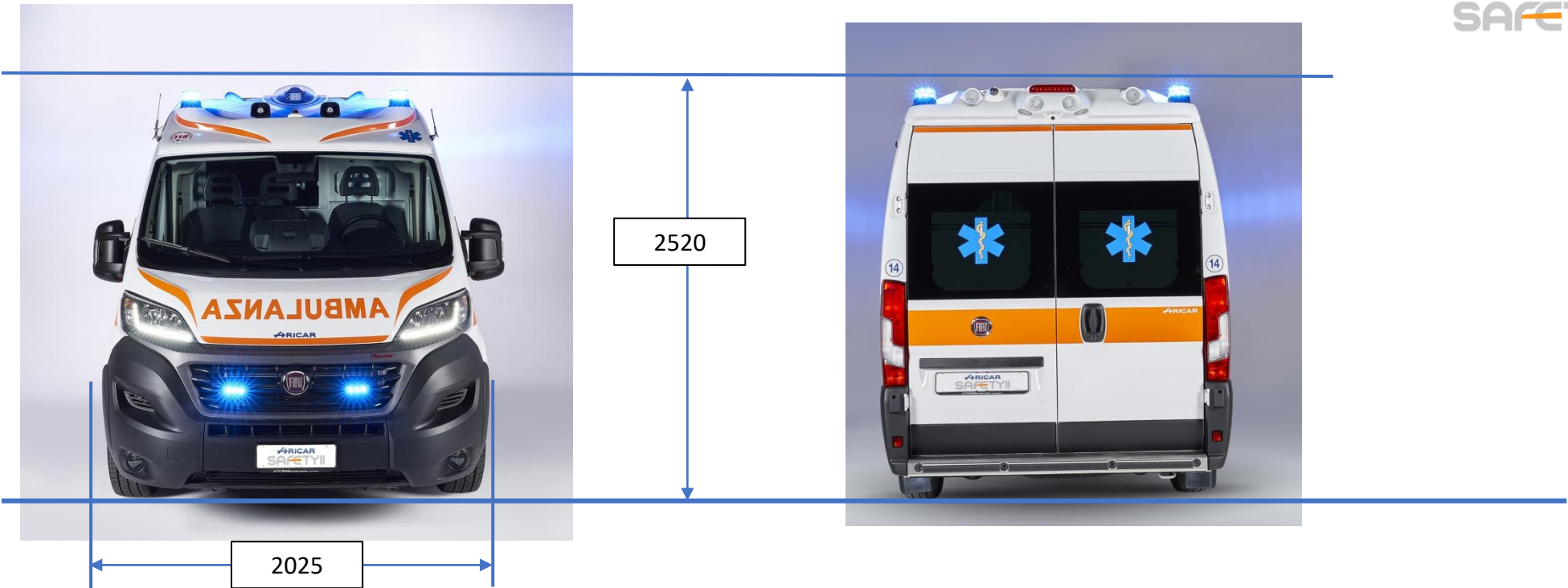

EXTERNAL DIMENSIONS





INTERIORS

SANITARY COMPARTMENT

- Interior designed according to the dimensional ratios of the vehicle with 3D modeling and rapid prototyping
- Access and exit spaces distinguished by the minimum dimensions of the equipment that make operating on the patient easier.
- No structural overhangs and no visible screws and bolts: **STRUCTURAL WELDS HAVE BEEN COMPLETELY ELIMINATED**
- ABS - ASA cladding parts and ultra-light aviation aluminium load-bearing structures glued to the bodywork
- Sophisticated ergonomics to optimise working space and access routes
- Wall units with automatic opening
- No through holes for fixing structural equipment such as seats, stretcher tops, furniture
- Spaces complying with EN 1789 and derived standards





THE PATIENT
COMPARTMENT:
A CONCENTRATE OF
TECHNOLOGY AND STYLE

- FULL LED LIGHTING
- ADJUSTABLE LIGHT INTENSITY SYSTEM FOR PHOTOSENSITIVE PATHOLOGIES
- LED SPOTLIGHTS WITH "SCIALYTIC" FUNCTION FOR CONCENTRATED LIGHTING IN THE STRETCHER AREA
- LED CRUISE NIGHT LIGHT
- "NO SHADOW" SYSTEM THAT AVOIDS SHADOWS ON THE PATIENT DURING MEDICAL ASSISTANCE



ROOF CABINETS

- "EASY OPEN" AUTOMATIC DOOR OPENING BY «EASY PUSH» BUTTON
- UPPER AND LOWER TRANSPARENT FRONTS FOR MATERIAL IDENTIFICATION
- INTERNAL LIGHTING SYSTEM BY MEANS OF LED WITH SANITIZABLE COVER
- REMOVABLE, INTERNAL "EASY FIX" TYPE ABS SEPARATORS
- HIGH RESISTANT STRUCTURES FOR MATERIAL CONTAINMENT IN CASE OF A CRASH
- POSSIBILITY OF HEATING AND COOLING OF THE HANGING COMPARTMENTS FOR STORING HEAT-SENSITIVE DRUGS

LEFT SIDE

Custom-designed furniture, built to offer maximum versatility of use and to meet the needs of customers; ultra-light "aviation" rack structures to contain resuscitation and medical equipment on board with the possibility of relocating the shelves for medical equipment at will.



RIGHT SIDE

The study of ergonomics has allowed the optimisation of space, creating specific structures to contain the stretcher side rotating single-seaters; seats and ergonomic reclining and fold-down backrests to allow minimum space and maximum comfort of its occupants. Option to fit the "Slide Easy" system which allows the single-seater to slide transversally with respect to the axis of the stretcher. Configuration also available with **two-seater bench** with "split" top opening, ideal for containing bulky and not easy to place material.

ABS/ASA PARTITION

- "SPACE-SAVING" DESIGN FLUSH WITH THE SIDE DOOR
- OPENABLE, "PRIVACY" TEMPERED WINDOWS
- DOOR INTEGRATED IN THE PARTITION WITH ELECTRICAL OPERATION (ON REQUEST)
- INTEGRATED GLOVE COMPARTMENT, ALSO ACCESSIBLE FROM THE DRIVER'S CAB
- ARRANGEMENT FOR MOTORIZED WHEELCHAIRS AND STAIR DESCENDERS
- HIGH CAPACITY UPPER BLANKET COMPARTMENT WITH FRONT DOOR
- CONCEALED CYLINDER COMPARTMENT THAT CAN BE OPENED WITH QUICK RELEASE SYSTEM

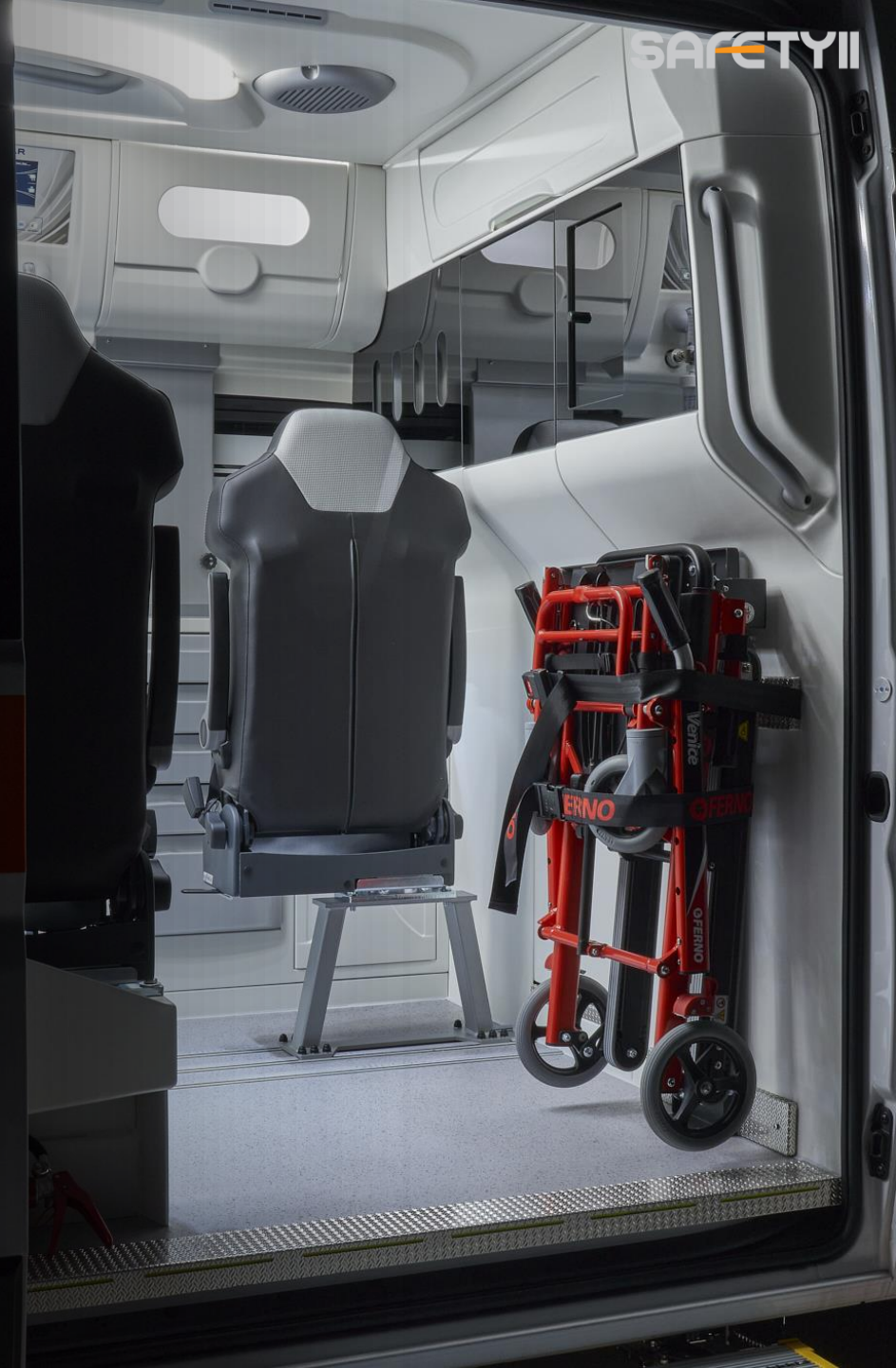



SEAT AT THE HEADER

- SINGLE-SEATER WITH INTEGRATED PRE-TENSIONED DOUBLE BELTS AND DOUBLE LATERAL RECEPTORS
- RECLINING AND FOLDING
- LIFTABLE SEAT WITH ANTI-ROLL GAS SPRINGS
- HYGIENIC TWO-COLOR COVERING
- LIFTABLE TWO-COLOR DOUBLE ARMREST
- ROTATING SYSTEM FOR DRIVER'S CAB ACCESS





COMPARTMENTS AND STRUCTURES

Everything is designed to meet a precise need: to safely contain fittings and equipment. Drawer cabinets, compartments for portable cylinders, wastebasket, mattress compartments, are elements of primary importance in emergency phases; thanks to the Olmedo atelier, specific furniture and structures dedicated to particular arrangements of sanitary material may be produced on request.



THE UPHOLSTERY: THE NEW TWO-COLOUR "BLACK/SILVER" COVERINGS

- The enhanced strength of upholstery required as a result of increasingly heavy-duty services combined with a brighter sanitary compartment introduced on **SafetyII** MY's TAF LINER upholstery the color "Professional Silver," to match the black already found on previous versions. It is a washable nautical fabric with high resistance, class 1, which can be sanitised even with very aggressive detergents and indicated for sanitation of the sanitary compartment after "Covid" services.

THE AVIO FLOOR: NO HOLES NEEDED AND MAXIMUM LIGHTWEIGHT

AVIO aluminum alloy FLOOR, aeronautical type, is ultralight, fireproof and 20G tested. It is equipped with integrated self-cleaning double groove type rails (increased depth for easily removable dirt deposits), compatible with 20G sealed gliders dedicated to the fixing of the sideshifter and the seat in the header. The structure is fixed to the floor of the vehicle by gluing (no through-holes) guaranteeing flexibility of the body, soundproofing, impossibility for liquids, detergents and disinfectants to enter, even aggressive ones. The application of upholstery and sideshifter by means of the gliders systems ensures easy disassembly from the sanitary compartment of all equipment applied on the ground, allowing minimum machine downtime in case of maintenance or bench checks of equipment. The applied washable anti-slip type of flooring is anti-static and allows for quick replacement in the event of wear or critical events by new flooring application. This is thanks to the "Easy Strap" technology of the cladding coupled to the underlying aluminium flooring by means of special certified adhesive systems.

M1
TESTED

Floor cover

HandiFloor™
+ HandiMastic

Vehicle body

Reinforcement kit

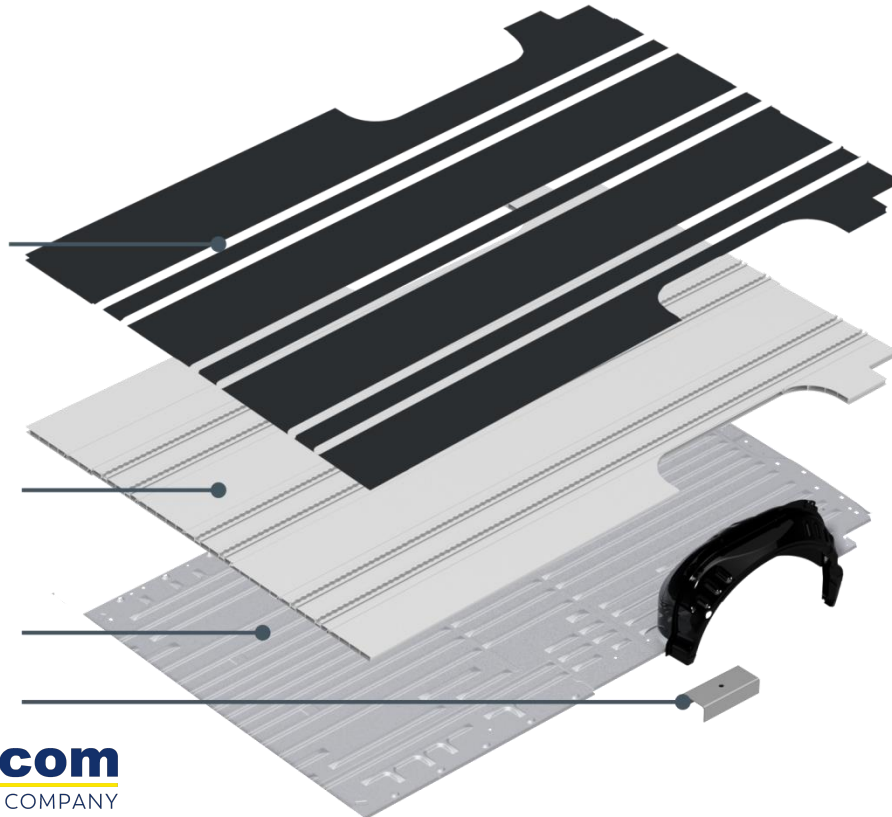

FRS AVIO RACKS: LIGHTWEIGHT, FLEXIBILITY AND SAFETY

The new monoblock structure for supporting AVR electro-medical equipment - **“Avio Rack System”**, is 20G certified and made of avio aluminium, lighter and more performing. Characterized by two lateral guides, it allows the movement along the whole length of the rack and its peculiarity is to make interchangeable all the electromedical equipment, from rack to rack and from ambulance to ambulance (if the rack is the same type). In addition, the rack can be mounted either vertically or horizontally, allowing for different mounting configurations.



THE INTEGRATED "BIO SAFE" SYSTEM: HEALTHY AIR IN THE SANITARY COMPARTMENT

BIO SAFE is the sanitisation system of the air introduced in the passenger compartment that exploits the natural effect of **photocatalysis** combined with **UV-A and UV-C irradiation** thanks to which a particular substance, the catalyst, for example WO_3 , when exposed to light irradiation, activates a **strong oxidative process** that leads to the transformation of harmful organic and inorganic substances into harmless compounds. The nanoparticles of the catalyst are applied on a support crossed by the air flow; when they are irradiated by special LEDs, they react with the humidity present giving rise to free radicals, very short-lived but very reactive, which attack and decompose harmful substances. **UV-A and UV-C** rays placed along the air path, controlled by the ambulance software, kill moulds and bacteria and other microorganisms by means of **germicidal lamps** and also kill pathogens or render them essentially harmless. **BIO SAFE** is an integrated system to the air conditioning system, which can be enabled on request during the configuration phase of your ambulance.

BIOSAFE



**NEGATIVE PRESSURE
SYSTEM AVAILABLE
ON DEMAND**

Biohazard Protection Unit



NEGATIVE PRESSURE AMBULANCE

pktrucks.com
A GTE COMPANY

INNOVATION AND SAFETY: NEGATIVE PRESSURE

TIME IS LIFE

*The ambulance is probably the best tool for rescuing patients and transporting them quickly to hospital: it is an irreplaceable mission. Facing new highly contagious diseases such as the coronavirus, ordinary ambulances cannot guarantee prevention from the risks of contagion: the **Negative Pressure** ambulance, instead, is an effective solution to the problem.*

*The **Negative Pressure** system involves technologies developed to create a pressure in the sanitary compartment lower than the atmospheric pressure present outside.*

In addition, the system constantly introduces sanitised air into the sanitary compartment, which is sanitised again before being expelled outside, generating a constantly changing air flow with a high number of exchanges (AIR IN - AIR OUT).

In case of transfer of a sick person, or a person with a suspected infectious disease, the continuous air exchange inside the sanitary compartment minimises the risk of inhalation of infected air by the personnel on board.

*The **Negative Pressure** system, moreover, makes the driver's cab an environment immune to contamination, as the air flow, thanks to the effect of negative pressure, can only be directed from the driver's cab to the sanitary compartment and never vice versa.*

The new challenges of healthcare have begun and negative pressure is the first real response.



NP SYSTEM
NEGATIVE PRESSURE

HEALTH AND WELL-BEING



The ambulance compartment is an enclosed environment so the quality of the air inside it (Indoor Air Quality), in addition to the health effects, is crucial and has a fundamental influence on the performance and physical and mental wellbeing of the operators.

Several scientific studies have shown that **indoor air quality affects:**

Productivity, concentration, reaction time, level of motivation and satisfaction, job skills, days off, stress, increased health and care costs borne by the employee and the National Health Service (NHS)

Ensuring a good change of air, creating optimal microclimatic conditions and eliminating the recirculation function, **improves the dilution of pollutants** such as PM10-PM2.5 particulate matter, CO2, odours, relative humidity and reduces the presence of pathogens, bacteria and viruses.

To this end, **the ambulance has been designed with an innovative negative pressure system,** adopting technological solutions that reduce the risk of contamination while guaranteeing the occupational health of the health workers and the driver (in the driver's cab).

The flow of the incoming and outgoing air, the negative pressure that is created, the speed of the air in the environment and on the operator, the sterilization of the incoming and outgoing air and the chosen filters, make it possible to **eliminate pollutants of the external air,** to minimize the diffusion of potential bacterial contamination and to create those internal microclimatic conditions that ensure the ideal parameters of the psycho-physical well-being of the operators.

The system adopted does not use recirculation and generates a negative pressure to isolate the compartment from the external environment with the criteria that are applied in the technologies of containment systems in the agri-food, biomedical, pharmaceutical and clean-room industry.

THE FIRST ENVIRONMENTAL SYSTEM DEVELOPED FOR THE CONTAINMENT OF INFECTIOUS DISEASES IN AMBULANCES

- High protection level for operators during transport of infectious patients
- Better protection for the crew in the driver's cabin (driver and navigators) during the transport of patients with infectious diseases, thanks to the "constrained" airflow
- Sanitary compartment with high level of sanitized and constantly monitored air quality (healthy environment for operators in all conditions, even in the absence of patients)
- **Negative pressure** system developed to ensure a high number of air changes (over 25 per hour) inside the sanitary compartment minimizing the risk of infection for the operators on board
- The system guarantees a **constant introduction of sanitized air into the sanitary compartment** from the outside, systematically eliminating the air inside **with high frequency replacement cycles (about 30 per hour)**, thus limiting the time of contamination and the persistence of odours



OPERATING PRINCIPLE:

The "NP" negative pressure system makes the pressure in the vehicle lower than the external atmospheric pressure, so that the air current flows from "**outside to inside**" (**IN-OUT FLOW**). In addition, the incoming air, previously sanitized by special filters, UV irradiation and photocatalysis, is purified before being discharged externally, thus avoiding external contamination from the exhaled air.

At this point, the outgoing flow depending from the negative pressure system compared to the air introduced by the sanitized air inlet system, generates a constant "circuit" of air change in the sanitary compartment, with a high flow and frequency. The treated and sanitized air coming from outside comes out from the roof duct of the sanitary compartment and, finding a lower pressure, is expelled according to a pressure delta from 10Pa to -38Pa, thus guaranteeing a complete change of air in the sanitary compartment every 2 minutes (30 times per hour).

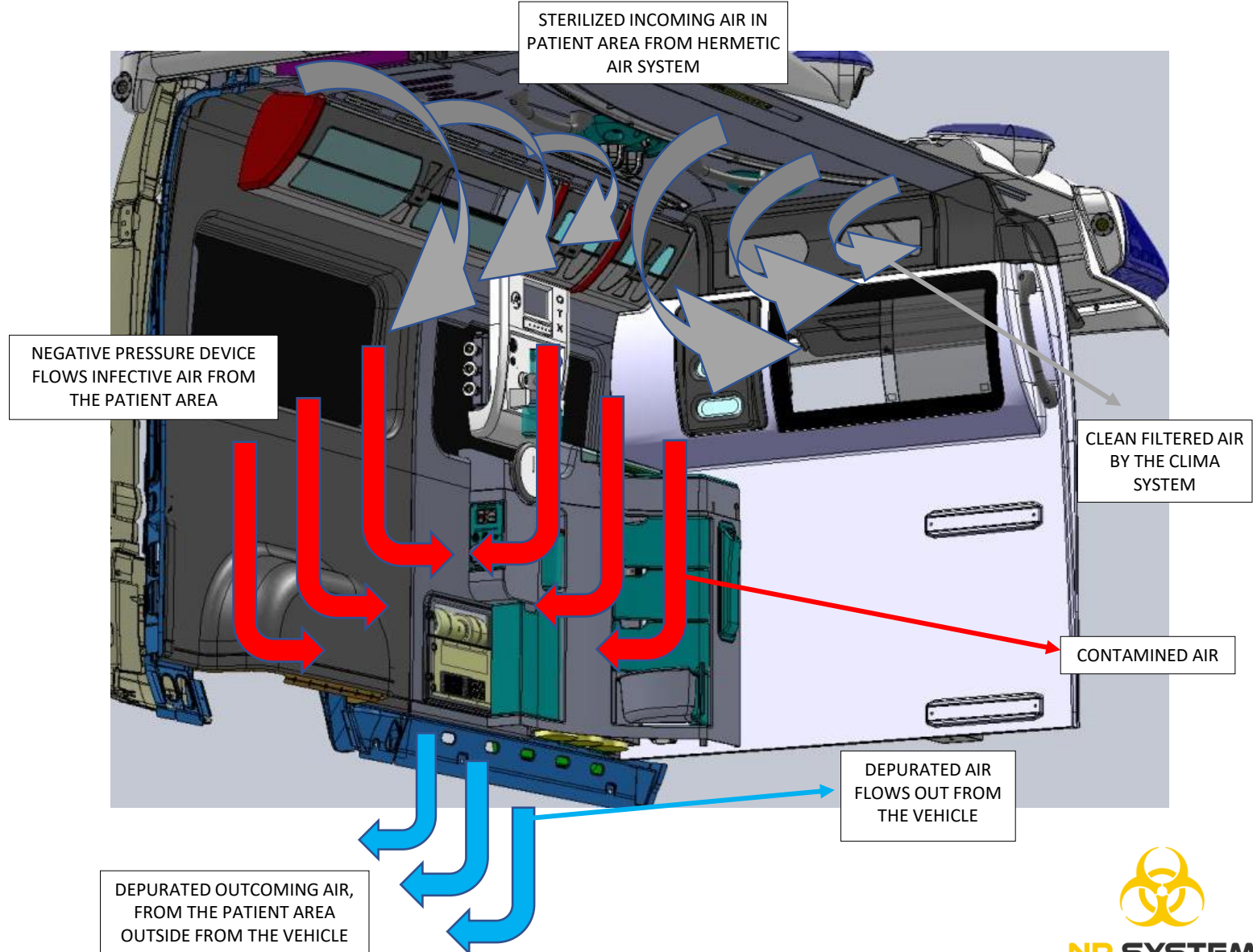

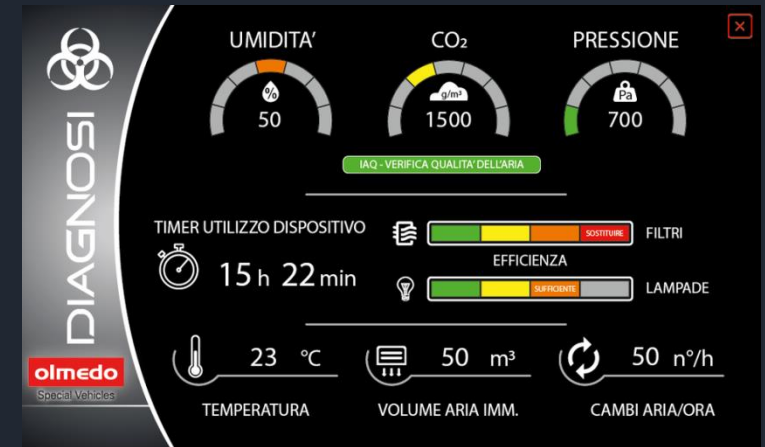

INTERACTIVE DIAGNOSIS SYSTEM

The NP System includes **THE MOST ADVANCED TECHNOLOGY** for the reading of the environmental parameters inside a rescue vehicle, completely in favour of the operators and patients safety, thanks to a software properly developed to read in real time the environmental parameters of the sanitary compartment. This is done by reading in real time the data transmitted by certified sensors, positioned in crucial points of the working area.

The air quality reading provides an **instant visualization** of the environmental condition of the operators, through a 10" colour display that shows in an intuitive way the environmental data, the IAQ level, the time of use, the filters/lamps wear and the specific diagnosis pages. The System is able, with an implementation already foreseen in the X.LINK 2.0 system, to send the environmental data of the ambulance in real time to the central unit, creating an environmental track of the vehicle.

The AUTO function ensures constant operation and eliminates the risk of "failure to switch on"; in this mode, the system is able to switch itself on if the air quality level degrades while the ambulance is in use.

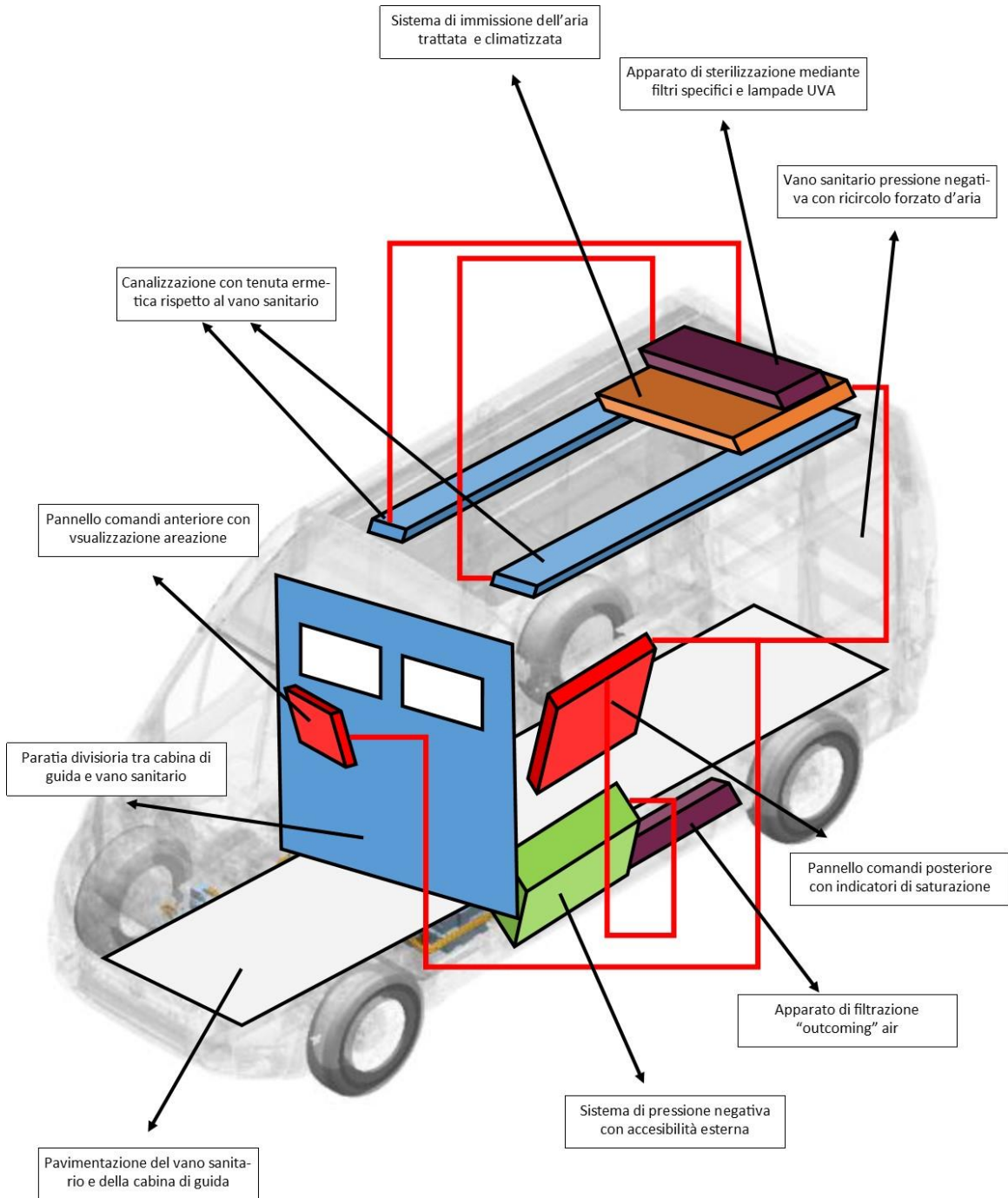

ALL IN ONE:
 VENTILATION
 AERATION
 SANITATION
 CONDITIONING
 PURIFICATION

A HEALTHIER WORKING ENVIRONMENT

- TECHNICAL FILE INCLUDING A **RISK-ANALYSIS PROTOCOL** FOR PERSONNEL WORKING INSIDE THE VEHICLE
- OFFICIAL LABORATORY DATA ENABLING A HEALTHY AND MONITORED WORKING ENVIRONMENT, WHICH CAN GREATLY INCREASE THE LEVEL OF OPERATORS' WELL-BEING
- CONSTANT AIR CHANGES CREATE OPTIMAL MICROCLIMATIC CONDITIONS AND BY ELIMINATING THE RECIRCULATION FUNCTION, IMPROVE THE DILUTION OF POLLUTANTS SUCH AS PARTICULATE MATERIAL, ODOURS, HUMIDITY AND THE PRESENCE OF PATHOGENS, BACTERIA AND VIRUSES
- AN EVEN HIGHER SAFETY LEVEL FOR THE DRIVER AND CREW IN THE DRIVER'S CABIN



FRONT CONTROL PANEL

- 7" ROOF-MOUNTED TOUCH SCREEN PANEL WITH INTEGRATED LIGHT
- HIGH EFFICIENCY BACKLIGHTING WITH ANTI-GLARE AND TWILIGHT SYSTEM
- INCREASED SENSITIVITY FOR USE EVEN WITH STERILE GLOVES AND PPE
- PROFESSIONAL SURFACE WITH HIGHLY EFFICIENT FOUR-COLOR ICONS
- LOW PROFILE STRUCTURE
- INTEGRATED BUZZER FOR ACOUSTIC ALERTS





REAR CONTROL PANEL

- 7" INTEGRATED PANEL COMBINED WITH "EASY ACCESS" BISTABLE BUTTON CONTROLS
- NEW 10" PANEL (OPTIONAL) WITH INCREASED SENSITIVITY AND PROFESSIONAL SURFACE
- HIGH EFFICIENCY BACKLIGHTING WITH ANTI-GLARE AND TWILIGHT SYSTEM
- INCREASED SENSITIVITY FOR USE EVEN WITH STERILE GLOVES AND PPE
- PROFESSIONAL SURFACE WITH HIGHLY EFFICIENT FOUR-COLOR ICONS
- LOW PROFILE STRUCTURE
- INTEGRATED BUZZER FOR ACOUSTIC ALERTS





CITY
STYLE

SAFETYII

LA TUA AMBULANZA 2.0