



<p align="center"><b>EMPL Recovery Vehicle, EH/W 200 BISON on Iveco Trakker 6x6– Heavy Range TB 220.187</b></p>
---

mounted on suitable Trakker AD380T42WH 6x6 chassis, wheelbase minimum 4.500mm, including PTO NH1C, 9ton front axle and 2x13ton rear axle with suitable tyres and rims, side marking lights and spare wheel to be delivered loose with chassis;

Purpose of superstructure:

A specially designed fully hydraulic underlift for recovering and transporting of stranded vehicles like passenger cars, buses, heavy trucks, tractor-trailer combinations, semi-trailers a.s.o. It is operated by the power take-off (PTO) of the truck chassis. FULLY HYDRAULICALLY OPERATED SYSTEM!

Subframe:

Subframe manufactured from rectangular steel profiles, mounted onto the truck chassis according to the regulations of the chassis manufacturer.

Main boom:

The main boom is built of rectangular steel profiles and is equipped with a reinforced mounting plate for the main recovery winch at the front end. Lifting of main boom is effected by two hydraulic cylinders. A rope guide roller (propeller pulley 360 degrees) is mounted on the rear end of the main boom, to support and guide the steel wire of the main recovery winch.

- Max. lifting angle of main boom approx. 25°

Folding boom in “SUPER SLIM DESIGN”:

The folding boom is built of rectangular steel profiles and is equipped with two boom extensions, extended and retracted by a heavy duty double acting hydraulic cylinder. The construction height of the boom extensions is specially designed for vehicles with low ground clearance! The folding boom is connected to the main boom and hydraulically foldable by the tilting cylinder.

- Max. outreach from folding boom bearing to centre of lifting forks approx. 4.100 mm
- Max. outreach from folding boom bearing to centre of wheel grid approx. 4.400 mm
- Max. hydraulic extension approx. 2.400 mm
- Max. tilting angle of folding boom approx. 90°
- Min. tilting angle of folding boom approx. - 5°
- Max. height of 1st boom / 2nd boom extension approx. 192 mm/ 148 mm

Special “POWER-TILT” function of folding boom

Due to the hydraulic system with integrated load holding valves, the underlift boom extension and the folding boom can be moved and held in every position under full load without mechanical locking device! A load holding valve secures the folding boom in transport position without mechanical locking device.

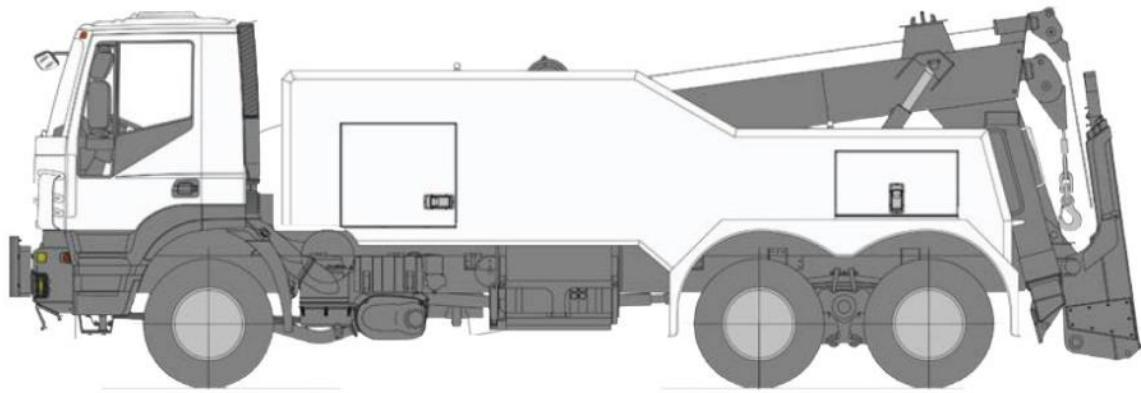

**Drawing is a sample only**

**Indicative load diagram in driving condition:**

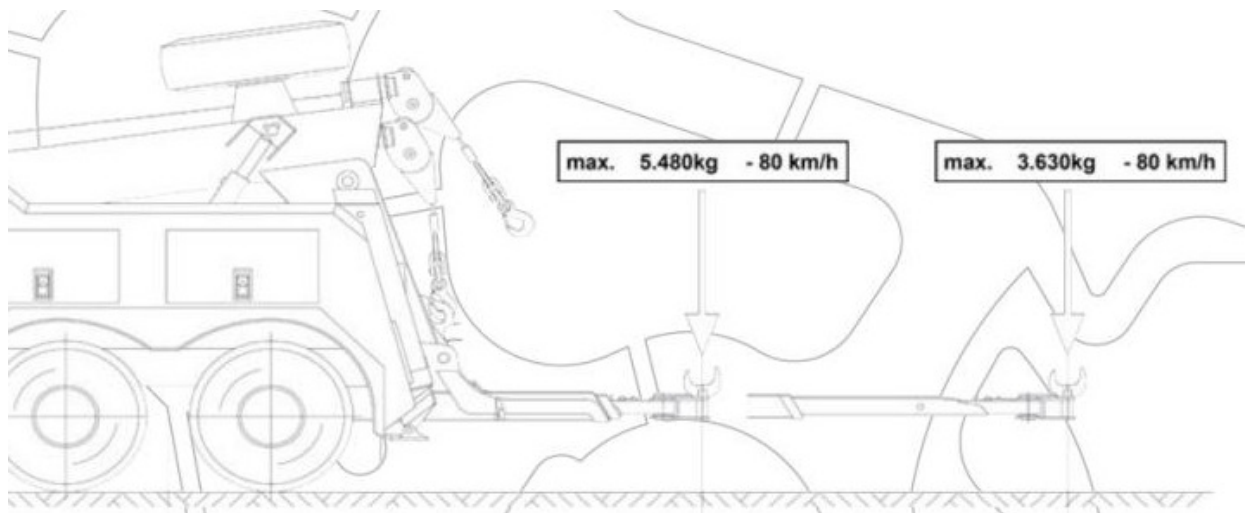

*Suspendable towing weight increases, when speed is reduced.*

System dimensions:

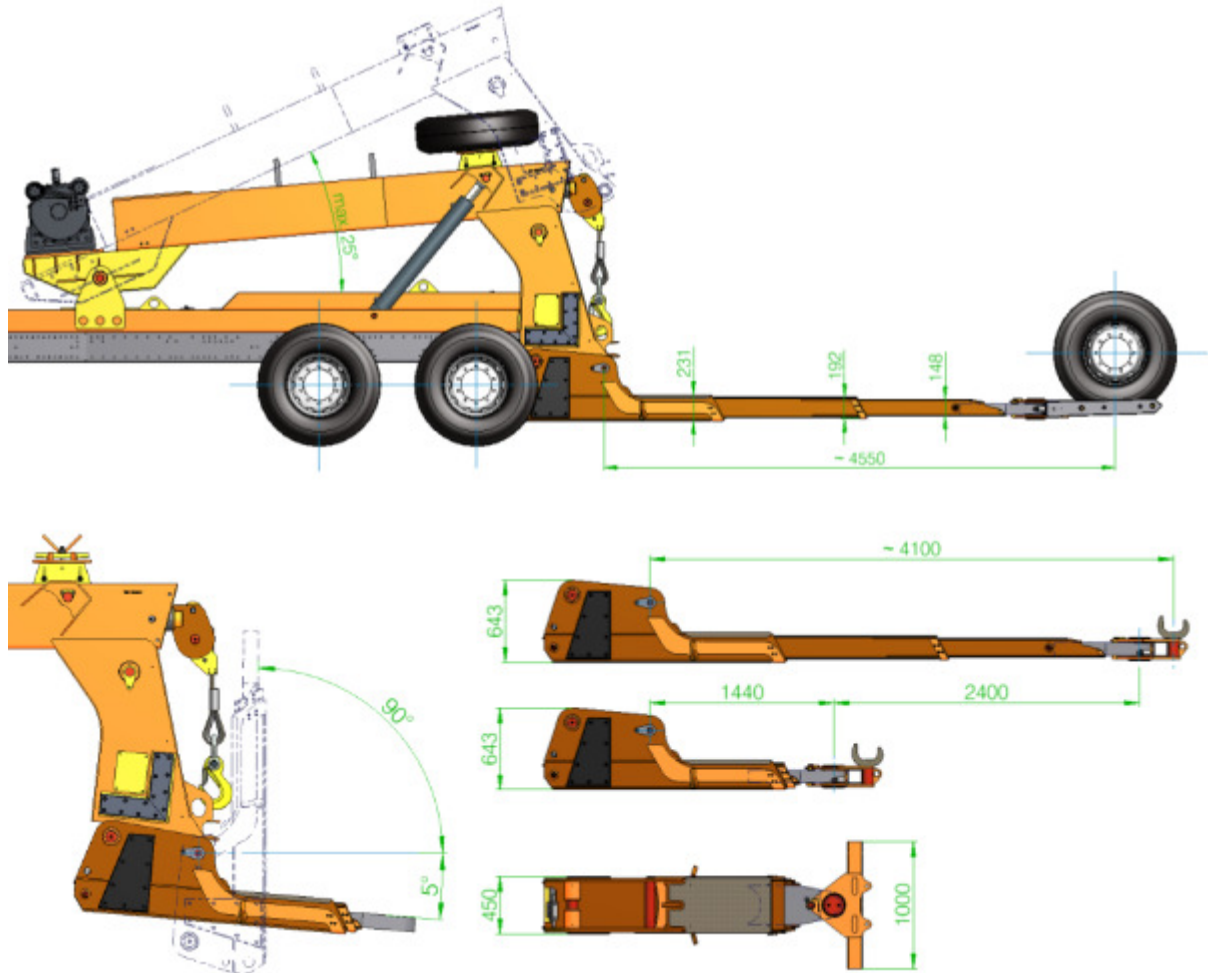

Maximum lifting capacities of recovery system (vehicle supported / rear stabilisers down)

- Underlift retracted - Folding boom capacity approx. 20 to
- Underlift retracted - Main boom capacity approx. 16 to
- Folding boom extended - capacity approx. 10 to

Recovery capacities while driving

- Max. recovery capacity while driving\* approx. 6 – 12,5 to

*\* final recovery capacity while driving depends on the technical capacities of the truck chassis (axle configuration and max. technical capacities rear/front, wheelbase, tyres/rims, driving speed, chassis curb weight,...) and needs to be calculated individually!*

### Main Recovery Winch – 20 to capacity:

The main recovery winch is executed as drum winch and is mounted at the front end of the main boom. The winch rope is guided to the rear of the main boom and leads into the rope guide roller. The provided distance between winch drum and rope guide roller ensures optimum rope spooling. The winch is powered by hydraulic motors and equipped with a hydraulically released spring-loaded automatic rope brake. The rope is equipped with a pressed-on thimble, shackle and hook.

### Technical data:

• Pulling force bottom rope layer	approx.	200	kN
• Pulling force top rope layer	approx.	130	kN
• Rope speed in low gear, bottom rope layer	approx.	3,0	m/min.
• Rope speed in low gear, top rope layer	approx.	5,0	m/min.
• Rope speed in high gear, bottom rope layer	approx.	10,0	m/min.
• Rope speed in high gear, top rope layer	approx.	15,0	m/min.
• Rope diameter		24	mm
• Rope length		50	m

### Unwinding manually:

The winch is equipped with a pneumatic operated dog clutch to allow free-spooling of wire-rope drum. Two- hand safety-control for winch free spool activation!

### Main control panel:

- Main hydraulic control block mounted in the rear end stowage compartment on the right hand side
- Switch for free spool device of hydraulic main winch
- Switches for interior illumination of stowage compartments
- Switches for working spotlights
- Emergency Stop

Switch for Illumination

Switch for free spool device

Emergency Stop

Main hydr. control block



#### Hydraulic system:

- Hydraulic oil tank with filling and return filter including oil level indicator
- Hydraulic constant pump, connected to the chassis PTO, with built in high pressure filter
- All hydraulic functions are equipped with load holding valves to:
  - prevent pressure loss in the hydraulic system in case of hose damage
  - prevent damage from return pressure

#### Rear stabilisers:

Two hydraulically operated stabilisers with spades for ground anchoring are mounted at the rear end of the body:

- Support width approx. 2.450 mm
- Independently operated by hydraulic cylinders with system-integrated block-valves to prevent uncontrolled movement of the stabilizers
- Foldable spades for use on asphalt or off-road
- 4 lashing rings (2 each side), 8,0 to each



#### Basic stowage compartments (Type 1):

The body is completely covered with steel panels along both sides with one stowage compartment each side, integrated at the front end. The main operator panel is integrated in a separate compartment at the right hand rear end of the body. Rear mounted steps with handles on both sides provide easy access to the body (Anti-slip cover on all walkable surfaces). Mud guards with rubber flaps for the rear axles of the truck chassis are integrated in the side steel panels.

All compartments are equipped with:

- Flappable and lockable steel doors and/or flaps
- Floor covered with rubber mats
- Master key system for all doors
- Gas pressure springs (to hold doors in opened position)
- Internal illumination for night operation
- Air ventilation grills (at back side)
- Stowage brackets for basic equipment
- Bracket for wheel chocks (wheel chocks to be delivered by truck manufacturer)
- Licence plate holder
- Detachable ladder incl. bracket





Illumination:



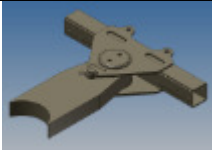
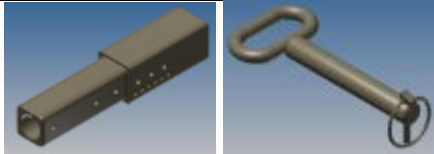
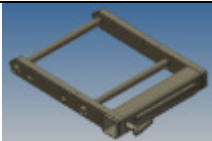

The basic illumination is executed according to the latest standards and is individually harmonized with the truck chassis and the local road regulations in the country of operation.

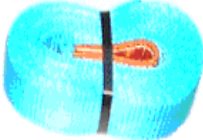

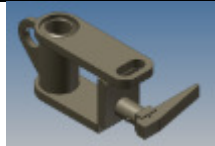
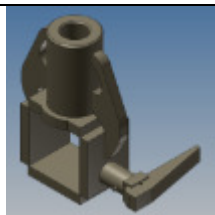
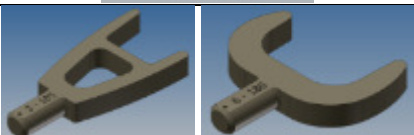

The following items are included in the basic execution:

- Delivery and mounting of 2 turnable working spot lights at the rear
- Installation of free delivered side marking lights (side marking lights to be delivered by the truck manufacturer), integrated in side panels
- Re-positioning of original truck chassis rear lights to the rear of side panels

Basic recovery accessories:

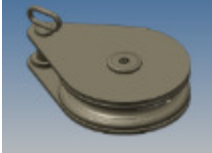
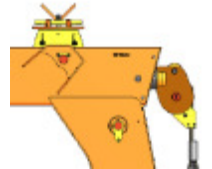

POS	Quantity	Description	Picture
1)	1	Multi-purpose lifting yoke, for quick adjustment	
2)	2	Lifting yoke extensions with fixing bolts	
3)	2	Adjustable wheel grids (left/right) in U-shape made of one piece including 4 setting rods (for different tyre sizes)	
4)	1	Bracket for lifting yoke extensions and wheel grids	
5)	2	Ratchets	
6)	1	Lever for ratchet	
7)	2	Wheel fixation belts with open end, L = 4.500 mm, for trucks and busses	
8)	2	Wheel fixation belts, for lateral fixation of truck tyres	

POS	Quantity	Description	Picture
9)	2	Wheel fixation belts, for small trucks and passenger cars	
10)	1	<u>Belt set including:</u> 2 Wheel lashing belts 4 Lashing belts with ratchet for wheel grid	
11)	2	Lifting fork adapters	
12)	2	Lifting fork adapters high execution	
13)	5	Pairs of different lifting forks (for supported tow underneath axles)	
14)	2	Lashing belts for lifting fork, L = 1.000 mm	
15)	2	Lashing belts with ratchet for lifting fork, L = 5.000 mm	

16)	1	<u>Set of towing bolts including:</u> <ul style="list-style-type: none"> <li>• 1 Towing bolt 39 mm with ball bearing for trailers</li> </ul>	
		<ul style="list-style-type: none"> <li>• 1 Towing bolt 49 mm</li> <li>• 1 Towing bolt 55,8 mm</li> <li>• 1 Adapter for towing bolts</li> </ul>	
17)	1	Tow bar, 2.250 mm, 32,0 tons pulling, DIN/NATO	
18)	1	Rope guide pulley for winch rope pulling near ground surface	
19)	1	Spare wheel bracket mounted on top of the main boom (spare wheel to be delivered loose by the truck manufacturer) including adapter	
20)	2	Wooden support chocks	



*Additional recovery accessories and equipment included as follows:*

EMPL #	Qty.	Description	Picture
930471	1	Max. ballast weight behind cab - front mounted depending on possibilities of chassis/cab and tyres for max. recovery capacity	
<b>Winch Accessories:</b>			
940354	1 Set	2x chain with hook and eye 2000mm, 2.500kg (WIN IA8W-HSW) 2x chain with hook and eye 2000mm, 6.700kg (WIN IA8W-HSW) 1x 2-strand chain with hook and eye 2000mm, 9,500 kg (WIN 13 II A8W-HSW) 2x RS-sling 5, 5.000kg, L = 4000mm 2x RS-sling 10, 10,000 kg, L = 4000mm 2x shackle curved 6.5 t 2x shackle curved 8.5 t 2x shackle curved 12t	
<b>Illumination / Safety equipment:</b>			
930912	1	Rear-equipment for vehicles which have to be recovered (following compulsory widenings and connections have to be delivered with the truck: 7-pin-socket, 2-line pneumatic connections)	
<b>Accessories:</b>			
930494	1	Brake hoses and illumination cables to recover trailers and semi-trailers	
940313	1	Radio remote control (for underlift system) – 5 functions: main boom, folding boom, underlift extension, 2 x winches (safety-control winch free spooling included)	

Painting:

- Shot blasting of all steel parts
- Epoxy Primer
- Polyurethane Paint Finish of recovery system in chassis frame colour
- Polyurethane Paint Finish of stowage compartments according to customers' choice - final RAL shade to be advised (metallic paint is not included in basic price and has to be offered optionally)
- Recovery accessories cathodic coated in black colour (cathodic dip-coating)

Preservation:

- All joints and hollow sections are preserved against corrosion by one layer of preservation wax
- Complete preservation of body with preservation wax

Marking / Labelling:

- EMPL Type Plate
- Labelling of all relevant operator information
- Safety warnings
- Anti-slip cover on all walkable surfaces

Documentation:

- Operator and Maintenance manual
- Hydraulic circuit diagram
- Wiring diagram
- Spare parts list
- All documents in English language, according to commercial standards
- 1 printed set each vehicle and 1 digital copy (in PDF format)
- 1 video on CD

***EMPL reserves the right to make technical modifications  
in view of its continuous product development.***

**Further included equipment & accessories:**

930475	Fix mounted flyer with light-bar and 2 integrated yellow rotating lights plus 2 search lights.
930501 940504	Main winch with 30 tons capacity instead of 20 tons including: 2 x RS 30 round sling, 30.000 kg, L = 4.000 mm 2 x shackle curved 30 tons
940286	Support winch, rear mounted, hydraulically operated Support winch required in case only one heavy duty winch is installed, to pull out heavy rope of main winch (in case main winch 30 tons)
931102	Special equipment set including following items: - 4 safety helmets - 4 pairs of gloves - 2 warning jackets - 2 warning beacons - 5 guiding cones with - 1 signal light battery-operated
931015	Camera rear mounted and monitor in driver cab

Sample Pictures:



*All above pictures and drawing are as sample only and might show additional equipment which is not included.*