

NEW EURO CARGO

TECHNICAL DESCRIPTION
EURO 3 M.Y. 2016



ML I80E28-E3 - Chassis Cab 4x2

The information in this literature is intended to be of a general nature only. IVECO reserves the right to modify or change specification at any time. All images are for illustrative purposes only.

IVECO

Your partner for sustainable transport

LIST OF LINKED VCB

VCB code	Gearbox	Wheelbase	Cabin	Drive
Z8NYC4C1	6S 1000 TO	3690	MLC-NM SX	LH
Z8NYC4F1	9S 1110 TO	3690	MLC-NM SX	LH
Z8NYC4T1	3000	3690	MLC-NM SX	LH
Z8NYC5C1	6S 1000 TO	4185	MLC-NM SX	LH
Z8NYC5C2	6S 1000 TO	4185	MLL-NM SX	LH
Z8NYC5F1	9S 1110 TO	4185	MLC-NM SX	LH
Z8NYC5F2	9S 1110 TO	4185	MLL-NM SX	LH
Z8NYC5T1	3000	4185	MLC-NM SX	LH
Z8NYC5T2	3000	4185	MLL-NM SX	LH
Z8NYC6C1	6S 1000 TO	4590	MLC-NM SX	LH
Z8NYC6C2	6S 1000 TO	4590	MLL-NM SX	LH
Z8NYC6F1	9S 1110 TO	4590	MLC-NM SX	LH
Z8NYC6F2	9S 1110 TO	4590	MLL-NM SX	LH
Z8NYC6T1	3000	4590	MLC-NM SX	LH
Z8NYC6T2	3000	4590	MLL-NM SX	LH
Z8NYC7C1	6S 1000 TO	4815	MLC-NM SX	LH
Z8NYC7C2	6S 1000 TO	4815	MLL-NM SX	LH
Z8NYC7F1	9S 1110 TO	4815	MLC-NM SX	LH
Z8NYC7F2	9S 1110 TO	4815	MLL-NM SX	LH
Z8NYC7T1	3000	4815	MLC-NM SX	LH
Z8NYC7T2	3000	4815	MLL-NM SX	LH
Z8NYC8C1	6S 1000 TO	5175	MLC-NM SX	LH
Z8NYC8C2	6S 1000 TO	5175	MLL-NM SX	LH
Z8NYC8F1	9S 1110 TO	5175	MLC-NM SX	LH
Z8NYC8F2	9S 1110 TO	5175	MLL-NM SX	LH
Z8NYC8T1	3000	5175	MLC-NM SX	LH
Z8NYC8T2	3000	5175	MLL-NM SX	LH
Z8NYC9C1	6S 1000 TO	5670	MLC-NM SX	LH
Z8NYC9C2	6S 1000 TO	5670	MLL-NM SX	LH
Z8NYC9F1	9S 1110 TO	5670	MLC-NM SX	LH
Z8NYC9F2	9S 1110 TO	5670	MLL-NM SX	LH
Z8NYC9T1	3000	5670	MLC-NM SX	LH
Z8NYC9T2	3000	5670	MLL-NM SX	LH
Z8NYCAC1	6S 1000 TO	6210	MLC-NM SX	LH
Z8NYCAC2	6S 1000 TO	6210	MLL-NM SX	LH
Z8NYCAF1	9S 1110 TO	6210	MLC-NM SX	LH
Z8NYCAF2	9S 1110 TO	6210	MLL-NM SX	LH
Z8NYCAT1	3000	6210	MLC-NM SX	LH
Z8NYCAT2	3000	6210	MLL-NM SX	LH
Z8NYCBC1	6S 1000 TO	6570	MLC-NM SX	LH
Z8NYCBC2	6S 1000 TO	6570	MLL-NM SX	LH
Z8NYCBF1	9S 1110 TO	6570	MLC-NM SX	LH
Z8NYCBF2	9S 1110 TO	6570	MLL-NM SX	LH

LIST OF LINKED VCB

Z8NYCBT1	3000	6570	MLC-NM SX	LH
Z8NYCBT2	3000	6570	MLL-NM SX	LH

DIMENSIONS & WEIGHTS

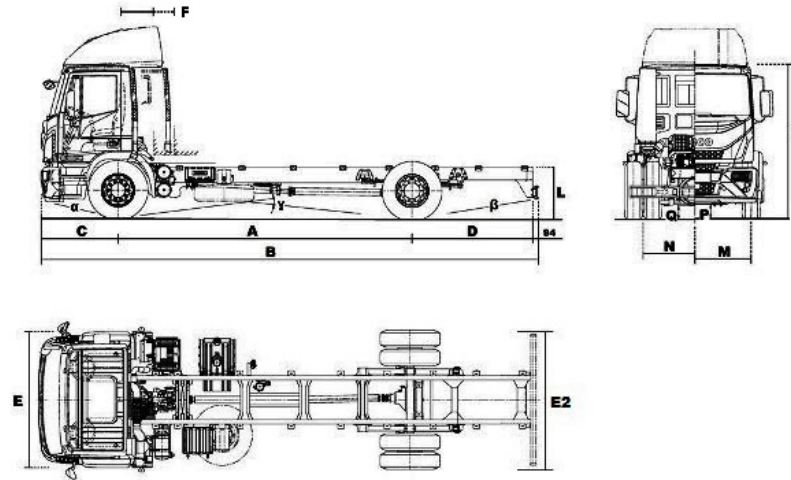

DIMENSIONS (MM)

Wheelbase (A)	3690 MLC	4185 MLC	4590 MLC	4815 MLC	5175 MLC	5670 MLC	6210 MLC	6570 MLC	4185 MLL	4590 MLL	4815 MLL	5175 MLL	5670 MLL	6210 MLL	6570 MLL
Max length (B)	6279	6954	7696	8124	8754	9361	9901	10801	6954	7696	8124	8754	9361	9901	10801
Max width over wings (cab) (E)	2390	2390	2390	2390	2390	2390	2390	2390	2390	2390	2390	2390	2390	2390	2390
Overall width (rear tyres) (E2)	2470	2470	2470	2470	2470	2470	2470	2470	2470	2470	2470	2470	2470	2470	2470
Front axle to back of cab - including filter (F)	620	620	620	620	620	620	620	620	620						
Front axle to front of body (H)										985	985	985	985	985	985
Frame height at end of frame, unladen (L)	1081	1081	1084	1085	1085	1084	1081	1083	1082	1085	1086	1087	1085	1082	1084
Frame height at front axle, unladen	1025	1022	1022	1021	1020	1018	1017	1016	1018	1018	1017	1016	1014	1012	1012
Frame height at rear axle, unladen	1068	1067	1067	1067	1066	1065	1064	1063	1067	1067	1067	1066	1065	1064	1063
Front overhang (C)	1362	1362	1362	1362	1362	1362	1362	1362	1362	1362	1362	1362	1362	1362	1362
Rear overhang (D)	1133	1313	1650	1853	2123	2235	2235	2775	1313	1650	1853	2123	2235	2235	2775
Minimum ground clearance (front) (P)	235	235	235	235	235	235	235	235	235	235	235	235	235	235	235
Minimum ground clearance (rear) (Q)	232	232	232	232	232	232	232	232	232	232	232	232	232	232	232

Overall height to top of cab, unladen (K)	2845	2842	2842	2841	2840	2838	2837	2836	2838	2838	2837	2836	2834	2833	2832
Turning diameter kerb to kerb	13190	14690	15920	16600	17700	19200	20800	21900	14690	15920	16600	17700	19200	20800	21900
Turning diameter wall to wall	14390	15900	17130	17810	18910	20420	22110	23210	15900	17130	17810	18910	20420	22110	23210
Front track (M)	1985	1985	1985	1985	1985	1985	1985	1985	1985	1985	1985	1985	1985	1985	1985
Rear track (N)	1820	1820	1820	1820	1820	1820	1820	1820	1820	1820	1820	1820	1820	1820	1820
Approach angle α (°)	12	12	12	12	12	12	13	12	12	12	12	12	12	13	12
Departure angle β (°)	16	14	12	10	9	9	9	7	14	12	10	9	9	9	7
Departure angle β * (°)	13	11	9	8	7	7	6	6	11	9	8	7	7	6	6
Ramp angle γ (°)	19	16	15	14	13	12	12	11	16	15	14	13	12	12	11
Side members thickness	6	7.7	7.7	7.7	7.7	7.7	7.7	7.7	7.7	7.7	7.7	7.7	7.7	7.7	7.7
Side members max height	274.5	277.9	277.9	277.9	277.9	277.9	277.9	277.9	277.9	277.9	277.9	277.9	277.9	277.9	277.9
Side members flange width	80	80	80	80	80	80	80	80	80	80	80	80	80	80	80
Frame width at rear	840	840	840	840	840	840	840	840	840	840	840	840	840	840	840

WEIGHTS (KG)

Wheelbase	3690	4185	4590	4815	5175	5670	6210	6570	4185	4590	4815	5175	5670	6210	6570
	MLC	MLC	MLC	MLC	MLC	MLC	MLC	MLC	MLL	MLL	MLL	MLL	MLL	MLL	MLL
Total vehicle kerb weight	5320	5430	5440	5490	5540	5655	5755	6815	5560	5570	5620	5670	5785	5885	5945
Kerbweight on Front Axle	3430	3510	3520	3550	3575	3635	3670	3690	3625	3635	3665	3695	3755	3790	3810
Kerbweight on Rear Axle	1890	1920	1920	1940	1965	2020	2085	2125	1935	1935	1955	1975	2030	2095	2135
G.V.W. (EC)	18000	18000	18000	18000	18000	18000	18000	18000	18000	18000	18000	18000	18000	18000	18000
G.V.W. (Design)	18000	18000	18000	18000	18000	18000	18000	18000	18000	18000	18000	18000	18000	18000	18000
Plated weight on front axle (EC)	7100	7100	7100	7100	7100	7100	7100	7100	7100	7100	7100	7100	7100	7100	7100
Plated weight on front axle (Design)	7100	7100	7100	7100	7100	7100	7100	7100	7100	7100	7100	7100	7100	7100	7100
Plated weight on rear axle(s) (EC)	11500	11500	11500	11500	11500	11500	11500	11500	11500	11500	11500	11500	11500	11500	11500
Plated weight on rear axle(s) (Design)	11500	11500	11500	11500	11500	11500	11500	11500	11500	11500	11500	11500	11500	11500	11500
Max body & payload (Design)	12680	12570	12560	12510	12460	12345	12245	11185	12440	12430	12380	12330	12215	12115	12055

MLC

Wheelbase	Type	Drawing
3690	Left hand drive	5802257660
4185	Left hand drive	5802257661
4590	Left hand drive	5802257662
4815	Left hand drive	5802257663
5175	Left hand drive	5802257664
5670	Left hand drive	5802257665
6210	Left hand drive	5802542152
6570	Left hand drive	5802257667

MLL

Wheelbase	Type	Drawing
4185	Left hand drive	5802257661
4590	Left hand drive	5802257662
4815	Left hand drive	5802257663
5175	Left hand drive	5802257664
5670	Left hand drive	5802257665
6210	Left hand drive	5802542152
6570	Left hand drive	5802257667

Notes : Weights are standard configuration and include: chassis cab, driver (75 Kg.), full fuel tank, oils,tools kit and spare wheel

(if present). The values of GVW / GCW can vary according to the markets and the homologations. The height of the side

member includes the thickness as well.

MODEL COMPONENTS

ENGINE

Manufacturer	IVECO
Commercial name	TECTOR
Position	FRONT
Cycle	DIESEL
Aspiration type	TC+AFTERCOOLER
Injection type	DIRECT
4 Stroke / 2 Stroke cycle	4
No. of cylinders	6
Cylinders layout	IN-LINE
Valves per cylinder	4
Bore mm	102
Stroke mm	120
Total displacement cm ³	5880
Weight (without oil / water) Kg	510
Oil capacity (l)	11.8
Type of fuel	DIESEL OIL
Injection system	HIGH PRESSURE / COMMON RAIL
Injection governor type	ELECTRONIC INTEGRATED WITH ECU
Cold starting type	THERMOSTARTER
Emissions control	EURO3
Speed limiter (Km/h)	90
Cruise control	All Speeds
Engine brake power (kW)	150
Engine brake (rpm)	3200
Cooling system	water
Fan type	viscstatic
Air intake	WITH SNORKEL
Snorkel position	Behind the cab, left side
Filter type	Dry - Heated
Air filter position	Behind the cabin

F4A 6 cylinder 202 kW rating

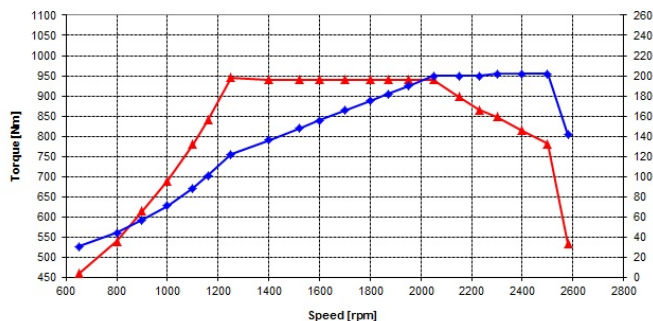

280 E3 - Motore Tector6 - 5,9 l - 202Kw

Maximum power: 202 kW (275 HP) @ 2500 rpm

Maximum torque: null Kgm (930 Nm) @ 1250 rpm

MODEL COMPONENTS**DRIVELINE****GEARBOX**

Gearbox model	Gearbox Type	Installation	Box material	Total ratio speed	Dry weight Kg	Max input torque Nm	No. of forward gears	No. of reverse gears	No. of synchro gears
3000	AUTOMATIC	ENGINE FLANGED	ALUMINIUM ALLOY	4.65	260 - (w/o retarder)	1261	5	1	--
6S 1000 TO	Mechanical SYNCRONIZED	ENGINE FLANGED	ALUMINIUM ALLOY	8.65	136	1050	6	1	6
9S 1110 TO	SYNCRONIZED	ENGINE FLANGED	ALUMINIUM ALLOY	12.64	136	1100	9	1	9

GEAR RATIOS

Gearbox model	1st	2nd	3rd	4th	5th	6th	7th	8th	9th	rev. 1st									
3000	3.49	1.86	1.41	1	0.75					5.03									
6S 1000 TO	6.75	3.6	2.12	1.39	1	0.78				6.06									
9S 1110 TO	9.48	6.58	4.68	3.48	2.62	1.89	1.35	1	0.75	8.97									

CLUTCH

Gearbox model	Type	Adjustment	Outer diameter mm	Outer diameter (inches)	Release control
3000	--	--	--	--	--
6S 1000 TO	SINGLE DRY PLATE	AUTOMATIC	395	15.5"	MECH./HYDRAULIC
9S 1110 TO	SINGLE DRY PLATE	AUTOMATIC	395	15.5"	MECH./HYDRAULIC

3000 Automatic gearbox:

* 300 kg with Hydraulic Retarder

HP	Model	Stall Torque Ratio:
220/250	TC415	2,35

REAR AXLE RATIO

Option code	00015 *	00737	00738 *	00739
Ratio	5.29	4.11	4.63	6.17

*: Standard axle ratio

TYRES & WHEELS

Code	Tyres	Front	Rear	Load index	Rolling circumference m
20498	Standard	295/80R22,5	295/80R22,5	152/148	3.184
20137	Optional	315/70R22,5	315/70R22,5	154/150	3.09
20146	Optional	315/80R22,5	315/80R22,5	156/150	3.28
20795	Optional	315/80R22,5	315/80R22,5	156/150	3.28
20143	Optional	295/80R22,5	295/80R22,5	152/148	3.184
20231	Optional	315/80R22,5	315/80R22,5	156/150	3.28
20230	Optional	305/70R22,5	305/70R22,5	152/148	3.045
20790	Optional	315/80R22,5	315/80R22,5	156/150	3.28
20041	Optional	315/60R22,5	315/60R22,5	152/148	2.88
20504	Optional	315/70R22,5	315/70R22,5	156/150	3.09
20757	Optional	12R22,5	12R22,5	150/146	3.305
20842	Optional	12R22,5	12R22,5	150/146	3.305

MODEL COMPONENTS

AXLES

Position	Description
Front	5871/5 - Iveco Axle
Rear	MS13-17X - Rear axle - Arvin Meritor - single reduction

PERFORMANCE

* Max Speed. Calculated speed on the basis of engine rpm and axle ratios. Real speed limits must take into account the speed index of the tyres: K = 110 km / h L = 120 km / h M = 130 km / h

** Theoretically calculated values, arising from the engine torque without considering the road-friction values and the stability limits of the vehicles. When calculating with more than one tyres or more than one axle ratio, availability of each combination must be checked.

Speed and gradeability values are rounded.

A = Total Weights (solo vehicle) Kg - Max Gradeability %

B = Total Weights (vehicle+trailer) Kg - Max Gradeability %

Tyre: 20498 - TYRES 295/80R22,5-152-FAST ON Efficiency: 0.85 No transfer box

Gearbox model 3000

Axle Ratio	Gear Ratio 1°	Gear Ratio 5°	Speed km/h 1°	Speed km/h 5°	RPM at 80 km/h	RPM at 90 km/h	A		B	
							18000		21500	
							1°	5°	1°	5°
4.11	3.49	0.75	33.30	154.94	1290	1451	12.12	1.50	10.03	1.16
4.63	3.49	0.75	29.56	137.54	1453	1635	13.77	1.98	11.40	1.56
5.29	3.49	0.75	25.87	120.38	1661	1868	15.88	2.53	13.15	2.02
6.17	3.49	0.75	22.18	103.21	1937	2179	18.72	3.21	15.49	2.59

Gearbox model 6S 1000 TO

Axle Ratio	Gear Ratio 1°	Gear Ratio 6°	Speed km/h 1°	Speed km/h 6°	RPM at 80 km/h	RPM at 90 km/h	A		B	
							18000		21500	
							1°	6°	1°	6°
4.11	6.75	0.78	17.22	148.98	1342	1510	24.60	1.66	20.31	1.29
4.63	6.75	0.78	15.28	132.25	1512	1701	28.03	2.14	23.09	1.69
5.29	6.75	0.78	13.38	115.75	1727	1943	32.52	2.70	26.70	2.16
6.17	6.75	0.78	11.47	99.24	2014	2266	38.80	3.40	31.66	2.75

Gearbox model 9S 1110 TO

Axle Ratio	Gear Ratio 1°	Gear Ratio 9°	Speed km/h 1°	Speed km/h 9°	RPM at 80 km/h	RPM at 90 km/h	A		B	
							18000		21500	
							1°	9°	1°	9°
4.11	9.48	0.75	12.26	154.94	1290	1451	35.91	1.50	29.39	1.16
4.63	9.48	0.75	10.88	137.54	1453	1635	41.28	1.98	33.59	1.56
5.29	9.48	0.75	9.52	120.38	1661	1868	48.56	2.53	39.17	2.02
6.17	9.48	0.75	8.17	103.21	1937	2179	59.36	3.21	47.14	2.59

Tyre: 20498 - TYRES 295/80R22,5-152-FAST ON Efficiency: 0.93 No transfer box

Gearbox model 3000

Axle Ratio	Gear Ratio 1°	Gear Ratio 5°	Speed km/h 1°	Speed km/h 5°	RPM at 80 km/h	RPM at 90 km/h	A		B	
							18000		21500	
							1°	5°	1°	5°
4.11	3.49	0.75	33.30	154.94	1290	1451	13.35	1.76	11.04	1.37
4.63	3.49	0.75	29.56	137.54	1453	1635	15.16	2.27	12.55	1.80
5.29	3.49	0.75	25.87	120.38	1661	1868	17.48	2.86	14.47	2.30
6.17	3.49	0.75	22.18	103.21	1937	2179	20.61	3.60	17.05	2.91

Gearbox model 6S 1000 TO

Axle Ratio	Gear Ratio 1°	Gear Ratio 6°	Speed km/h 1°	Speed km/h 6°	RPM at 80 km/h	RPM at 90 km/h	A		B	
							18000		21500	
							1°	6°	1°	6°
4.11	6.75	0.78	17.22	148.98	1342	1510	27.14	1.92	22.37	1.51
4.63	6.75	0.78	15.28	132.25	1512	1701	30.97	2.44	25.46	1.94
5.29	6.75	0.78	13.38	115.75	1727	1943	36.02	3.04	29.48	2.45
6.17	6.75	0.78	11.47	99.24	2014	2266	43.17	3.80	35.06	3.08

MODEL COMPONENTS

Gearbox model 9S 1110 TO

Axle Ratio	Gear Ratio 1°	Gear Ratio 9°	Speed km/h 1°	Speed km/h 9°	RPM at 80 km/h	RPM at 90 km/h	A		B	
							18000		21500	
							1°	9°	1°	9°
4.11	9.48	0.75	12.26	154.94	1290	1451	39.87	1.76	32.50	1.37
4.63	9.48	0.75	10.88	137.54	1453	1635	46.01	2.27	37.24	1.80
5.29	9.48	0.75	9.52	120.38	1661	1868	54.49	2.86	43.59	2.30
6.17	9.48	0.75	8.17	103.21	1937	2179	67.43	3.60	52.82	2.91

SUSPENSIONS

Front parabolic suspension :

No. of leaves: 4

Rear parabolic suspension :

No. of leaves: 2 + 1

ML DAY CAB MY2015

CAB EXTERIOR

Day cab and *sleeper cab :

Forward control cab.

Illuminated steps.

New front grid, new front bumper, new badging.

Pressed steel construction with SMC for vulnerable parts.

External sun visor as option.

Integrated sun visors filter as option (the integrated sun visors filter has been developed as alternative to the external sun visor in order to guarantee to the driver the same protection from the sun with a lower impact on CX factor and consequent reduced fuel consumption).

New handle with an improved ergonomics.

New side deflectors improving air flow keeping door handle clean.

Rear view mirrors:

Euro V range : standard : "mirror 2003/97/CE " (compliant with UNIECE 46)

Euro III range : standard : "tubular arms mirror" (compliant with 88/321/EC)

Cab height:

From ML110EL.. up to ML120EL.: 1 step

from ML120E.. up to ML180E.. and 4x4 models: 2 steps

Fully suspended cab (helical springs and dampers). Reinforced cab suspensions on 4x4 and ML150E..H /ML170E..H models.

Manual or servo assisted tilt to 60 degrees.

Sound and thermal insulation, bumper with integrated headlamps (standard in **plastic** for 4x2 - standard in **steel** for 4x4), spray suppression, 2-speed windscreen with intermittent function. Hood can be raised for daily checks.

Led Day Running Lights (available as option on all the models, except for 4x4 - ML150E..H - ML170E..H and chassiscowl models).

Xenon head lamps (available as option on all the models).

CAB INTERIOR

New standard contains:

New dashboard mold colour.

New light control switch.

New automatic and automated gearbox controls.

New central tunnel module with cup holders, 12 V plug, and ashtray cup.

New door panel (RHD only).

New seats trim.

New instrument Cluster.

Highline Cluster.

New steering wheel.

Two USB plugs.

MODEL COMPONENTS

New clima control switches.
New cards/coins holders.

Furthermore: overhead lockers with doors. Glove box. Four speed fan. All gauges monitored using international symbols. Column mounted control stalks. Overhead console for radio and CB. Digital monochrome display, radio preparation (cabling, speaker and aerial), D/N/R buttons for automatic & automated gearbox with manual override on steering column stalk. Dashboard gear lever for manual box. Body builder plug, Adjustable steering wheel. Electric windows. Smocking kit.

Available options:

Arm rest (for air suspended seats only).
High comfort driver seat.
Three way adjustable driver seat, dual fixed passenger seat.
Air compressor plug.
Immobiliser.
Central locking with remote control.
Additional cab heater.

Furthermore:

Day Cab standard contains:

Rear wall rail with hooks for clothes. Windowless rear wall with document net.

Available options for Day Cab:

New mobile office with integrated led light (2 seats configuration). Rear windows.

Sleeper Cab standard contains:

Courtesy and map reading lights. Bunk.

Available options for Sleeper Cab:

High roof. Additional bunk.

***Please be aware that the Sleeper cab is not available on road sweeper models**

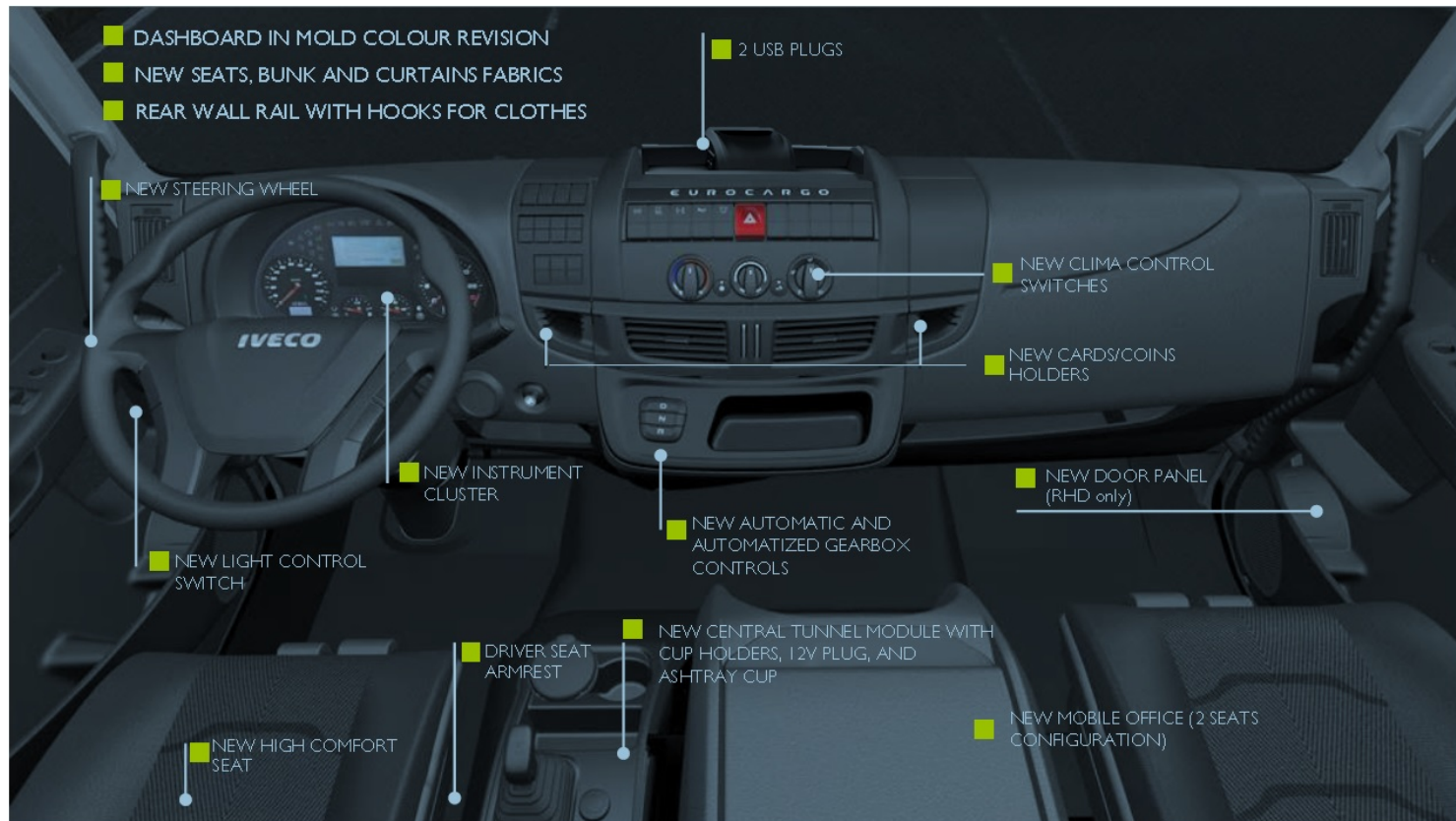

MODEL COMPONENTS

BATTERY

Electrics

Voltage V	24
No. of batteries	2
Batteries capacity V/Ah	12 V /120 Ah

Notes: Std. on all wheelbases except 4x2 model with 3105 mm wheelbase (models with mechanical suspensions)

MISCELLANEOUS

Fuelling :

Fuel tank 115 litres , plastic.

Disc Brake :

Diameter :
front 432 x 45 mm ventilated disc.
Friction area x wheel : 408 cm²
rear 432 x 45 mm ventilated disc.
Friction area x wheel : 408 cm²

Braking system :

Type : Full air. Two independent circuits.
Service brake : ABS + EBL (ESP as on option).
Parking : Spring parking brake on rear axle.
Emergency : Combined with parking brake.
Air reservoirs : 2 x 20 litres, steel (25 litres for vehicle with air suspensions).
Exhaust brake : Standard.
Air compressor : 225 cc single cylinder (360 cc as on option; standard with automatic gearbox).
Air drier : Air processing Unit (APU).



IVECO

Your partner for sustainable transport