

IVECO T-WAY

TECHNICAL DESCRIPTION



AD380T43 H - Chassis Cab 6x4

IVECO

LIST OF LINKED VCB

VCB code	Gearbox	Wheelbase	Cabin	Drive
VTDILIBI	I6S 2220 TO	3300	AD-SX	LH
VTDILIB3	I6S 2220 TO	3300	AD-SX	LH
VTDILIBA	I6S 2220 TO	3300	AD-DX	RH
VTDILIBC	I6S 2220 TO	3300	AD-DX	RH
VTDILIDI	I6TX 2240 TO	3300	AD-SX	LH
VTDILID3	I6TX 2240 TO	3300	AD-SX	LH
VTDILIDA	I6TX 2240 TO	3300	AD-DX	RH
VTDILIDC	I6TX 2240 TO	3300	AD-DX	RH
VTDIL2BI	I6S 2220 TO	3500	AD-SX	LH
VTDIL2B3	I6S 2220 TO	3500	AD-SX	LH
VTDIL2BA	I6S 2220 TO	3500	AD-DX	RH
VTDIL2BC	I6S 2220 TO	3500	AD-DX	RH
VTDIL2DI	I6TX 2240 TO	3500	AD-SX	LH
VTDIL2D3	I6TX 2240 TO	3500	AD-SX	LH
VTDIL2DA	I6TX 2240 TO	3500	AD-DX	RH
VTDIL2DC	I6TX 2240 TO	3500	AD-DX	RH
VTDIL3BI	I6S 2220 TO	3800	AD-SX	LH
VTDIL3B3	I6S 2220 TO	3800	AD-SX	LH
VTDIL3BA	I6S 2220 TO	3800	AD-DX	RH
VTDIL3BC	I6S 2220 TO	3800	AD-DX	RH
VTDIL3DI	I6TX 2240 TO	3800	AD-SX	LH
VTDIL3D3	I6TX 2240 TO	3800	AD-SX	LH
VTDIL3DA	I6TX 2240 TO	3800	AD-DX	RH
VTDIL3DC	I6TX 2240 TO	3800	AD-DX	RH
VTDIL4BI	I6S 2220 TO	4200	AD-SX	LH
VTDIL4B3	I6S 2220 TO	4200	AD-SX	LH
VTDIL4BA	I6S 2220 TO	4200	AD-DX	RH
VTDIL4BC	I6S 2220 TO	4200	AD-DX	RH
VTDIL4DI	I6TX 2240 TO	4200	AD-SX	LH
VTDIL4D3	I6TX 2240 TO	4200	AD-SX	LH
VTDIL4DA	I6TX 2240 TO	4200	AD-DX	RH
VTDIL4DC	I6TX 2240 TO	4200	AD-DX	RH
VTDIL5BI	I6S 2220 TO	4500	AD-SX	LH
VTDIL5B3	I6S 2220 TO	4500	AD-SX	LH
VTDIL5BA	I6S 2220 TO	4500	AD-DX	RH
VTDIL5BC	I6S 2220 TO	4500	AD-DX	RH
VTDIL5DI	I6TX 2240 TO	4500	AD-SX	LH
VTDIL5D3	I6TX 2240 TO	4500	AD-SX	LH
VTDIL5DA	I6TX 2240 TO	4500	AD-DX	RH
VTDIL5DC	I6TX 2240 TO	4500	AD-DX	RH

DIMENSIONS & WEIGHTS

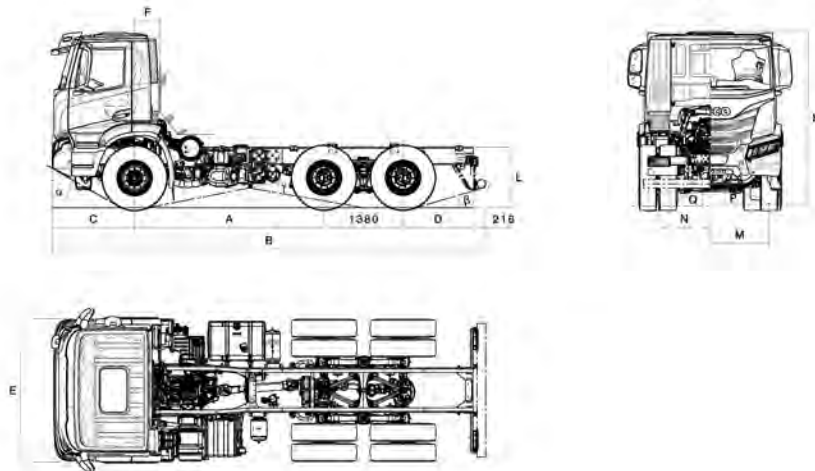

DIMENSIONS (mm)

Wheelbase (A)	3300	1380	3500	1380	3800	1380	4200	1380	4500	1380
Max length (B)	7572	8067	8337	8382	9102					
Max width over wings (cab) (E)	2550	2550	2550	2550	2550					
Front axle to back of cab - including filter (F)	445	445	445	445	445					
Frame height at end of frame, unladen (L) (drum brakes)	1159	1159	1159	1157	1158					
Frame height at end of frame, unladen (L) (disc brakes)	1160	1160	1160	1158	1159					
Frame height at front axle, unladen (drum brakes)	1121	1121	1121	1119	1119					
Frame height at front axle, unladen (disc brakes)	1121	1122	1121	1120	1119					
Frame height at rear axle, unladen (drum brakes)	1147	1146	1146	1147	1146					
Frame height at rear axle, unladen (disc brakes)	1148	1147	1147	1147	1147					
Front overhang (C)	1440	1440	1440	1440	1440					
Rear overhang (D)	1225	1495	1495	1135	1585					
Minimum ground clearance (front) (P)	337	337	337	337	337					
Minimum ground clearance (rear) (Q)	311	311	311	311	311					
Overall height to top of cab, unladen (K) (drum brakes)	3138	3138	3138	3136	3136					
Overall height to top of cab, unladen (K) (disc brakes)	3138	3139	3138	3137	3136					
Turning diameter kerb to kerb	16800	17400	18100	19100	19800					
Turning diameter wall to wall	18400	19000	19700	20700	21400					
Front track (M) (disc brakes)	2043	2043	2043	2043	2043					
Front track (M) (drum brakes)	2053	2053	2053	2053	2053					
Rear track (N) (disc brakes)	1827	1827	1827	1827	1827					
Rear track (N) (drum brakes)	1831	1831	1831	1831	1831					
Approach angle α (°)	30	30	30	30	30					
Departure angle β (°)	16	13	14	18	13					
Ramp angle γ (°)	21	20	20	21	21					

Side members thickness	10	10	10	10	10
Side members max height	309	309	309	309	309
Side members flange width	80	80	80	80	80
Frame width at rear	776	776	776	776	776

WEIGHTS (KG)

Wheelbase	3300 1380	3500 1380	3800 1380	4200 1380	4500 1380
Total vehicle kerb weight (drum brakes)	9319	9381	9424	9430	9530
Total vehicle kerb weight (disc brakes)	9229	9290	9334	9320	9440
Kerbweight on Front Axle (drum brakes)	5159	5145	5176	5246	5262
Kerbweight on Front Axle (disc brakes)	5143	5131	5162	5214	5254
Kerbweight on rear axle (drum brakes)	4160	4236	4248	4184	4268
Kerbweight on rear axle (disc brakes)	4086	4159	4172	4106	4186
G.V.W. (EC)	26000	26000	26000	26000	26000
G.V.W. (Design)	33500	33500	33500	33500	33500
Plated weight on front axle (EC)	8000	8000	8000	8000	8000
Plated weight on front axle (Design)	8000	8000	8000	8000	8000
Plated weight on rear axle(s) (EC)	19000	19000	19000	19000	19000
Plated weight on rear axle(s) (Design)	26000	26000	26000	26000	26000

Notes :

Weights are to standard configuration and include: chassis cab (or tractor), driver (75 kg), full fuel and Adblue tanks, tools kit and spare wheel (if present).
The values of the plated weights / GVW can vary according to the markets and local homologations.

Wheelbase	Type	Drawing
3300 1380	Left hand drive	5803034354
3500 1380	Left hand drive	5803034355
3800 1380	Left hand drive	5803034356
4200 1380	Left hand drive	5803034357
4500 1380	Left hand drive	5803034358

MODEL COMPONENTS

ENGINE

Identification Code	F3HGE611
Manufacturer	FPT Industrial
Commercial name	Cursor 13
Cycle	DIESEL
Injection type	DIRECT
4 Stroke / 2 Stroke cycle	4
No. of cylinders	6
Cylinders layout	IN-LINE
Bore mm	135
Stroke mm	150
Total displacement cm ³	12.882
Exhaust gas treatment	muffler
Weight (without oil / water) Kg	1230
Injection system	Common rail
Cold starting type	THERMOSTARTER
Emissions control	EURO V
Cooling system	water



ENGINE EMISSION EURO V opt. 06049

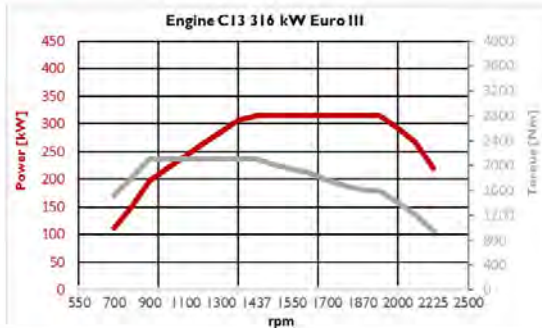

430 C13 - Cursor 13 - 430 CV - WG

Maximum power: 316 kW (430 HP) @ 1900 rpm

Maximum torque: 214 Kgm (2100 Nm) @ 1100 rpm

The central electronic system controls the following functions: Engine preheating, fuel preheating, turbo, injection control, engine brake, control of engine speed and torque, data exchange OBD with ScanTool, engine diagnostic (onandoff-board), control of blink-code and failure indicator light on dashboard, control of engine idling speed and max. engine speed, data exchange with VCM (vehiclecontrol module), supervision of emission values.

DRIVELINE

GEARBOX

Gearbox model	Gearbox Type	Installation	Box material	Dry weight Kg	Clutch type	Max input torque Nm	No. of forward gears	No. of reverse gears	Shifting
16S 2220 TO	SYNCRONIZED	ENGINE FLANGED	ALUMINIUM ALLOY	304.5 - (w/o retarder)	Dry clutch	2200	16	2	HH-Coupling control
16TX 2240 TO	AUTOMATED	ENGINE FLANGED	ALUMINIUM	290 - (w/o retarder)		2200	16	2	

GEAR RATIOS

Gearbox model	1	2	3rd	4	5	6	7	8	9	10	11	12	13	14	15	16 ^a	M.A. 1	M.A. 2		
16S 2220 TO	13.8	11.54	9.49	7.93	6.53	5.46	4.57	3.82	3.02	2.53	2.08	1.74	1.43	1.2	1.00	.84	12.92	10.8		
16TX 2240 TO	14.68	12.05	9.92	8.14	6.78	5.56	4.57	3.75	3.22	2.64	2.17	1.78	1.49	1.22	1.00	0.82	14.14	11.61		

CLUTCH

Gearbox model	Type	Outer diameter mm	Outer diameter (inches)			
16S 2220 TO	Single dry plate	430	17			
16TX 2240 TO	Single dry plate	430	17			

MODEL COMPONENTS

TYRES & WHEELS

Code	Tyres	Front	Rear	Load index	Rolling circumference m
20081	Standard	13R22,5	13R22,5	156/150	3.428
20885	Optional	385/65R22,5	315/80R22,5	164/	3.28
20795	Optional	315/80R22,5	315/80R22,5	156/150	3.28
20079	Optional	13R22,5	13R22,5	156/150	3.428
20497	Optional	12,00R20	12,00R20	154/149	3.42
20790	Optional	315/80R22,5	315/80R22,5	156/150	3.28
20216	Optional	12,00R20	12,00R20	154/149	3.42

REAR AXLE RATIO

Option code	05003	06017 *	06019	06021	06032	06034	06036
Ratio	6.09	4.23	4.67	5.01	3.792	5.56	6.57

*: Standard axle ratio

PERFORMANCE

* Max Speed. Calculated speed on the basis of engine rpm and axle ratios. Real speed limits must take into account the speed index of the tyres: K = 110 km / h L = 120 km / h M = 130 km / h

** Theoretically calculated values, arising from the engine torque without considering the road-friction values and the stability limits of the vehicles. When calculating with more than one tyres or more than one axle ratio, availability of each combination must be checked.

Speed and gradeability values are rounded.

A = Total Weights (solo vehicle) Kg - Max Gradeability %

B = Total Weights (vehicle+trailer) Kg - Max Gradeability %

Tyre: 20081 - 13R22.5 TYRES - Regional / Works **Efficiency: 0.91** **No transfer box**

Gearbox model I6S 2220 TO

Axle Ratio	Gear Ratio 1°	Gear Ratio 16°	Speed km/h 1°	Speed km/h 16°	RPM at 80 km/h	RPM at 90 km/h	A		B	
							26000		40000	
							1°	16°	1°	16°
3.792	13.8	0.84	7.47	122.69	1252	1408	100.00	3.27	52.51	1.88
4.23	13.8	0.84	6.69	109.98	1396	1571	100.00	3.87	60.79	2.27
4.67	13.8	0.84	6.06	99.62	1542	1734	100.00	4.45	70.14	2.65
5.01	13.8	0.84	5.65	92.86	1654	1861	100.00	4.89	78.30	2.93
5.56	13.8	0.84	5.09	83.67	1835	2065	100.00	5.58	94.02	3.38
6.09	13.8	0.84	4.65	76.39	2010	2262	100.00	6.24	100.00	3.80
6.57	13.8	0.84	4.31	70.81	2169	2440	100.00	6.82	100.00	4.18

Gearbox model I6TX 2240 TO

Axle Ratio	Gear Ratio 1°	Gear Ratio 16°	Speed km/h 1°	Speed km/h 16°	RPM at 80 km/h	RPM at 90 km/h	A		B	
							26000		40000	
							1°	16°	1°	16°
3.792	14.68	0.82	7.02	125.68	1222	1375	100.00	3.15	56.97	1.80
4.23	14.68	0.82	6.29	112.67	1363	1533	100.00	3.74	66.37	2.18
4.67	14.68	0.82	5.70	102.05	1505	1693	100.00	4.31	77.24	2.55
5.01	14.68	0.82	5.31	95.12	1614	1816	100.00	4.74	86.98	2.83
5.56	14.68	0.82	4.79	85.72	1792	2016	100.00	5.42	100.00	3.27
6.09	14.68	0.82	4.37	78.26	1962	2208	100.00	6.06	100.00	3.69
6.57	14.68	0.82	4.05	72.54	2117	2382	100.00	6.63	100.00	4.06

FRONT BUMPER

Steel front bumper

MODEL COMPONENTS

DISC BRAKES

DUO DUPLEX drum brake
Electronic braking system (EBS)

Front axle
Drum brakes 410 mm (410 x 180)
Friction area: 2884 cm²

Tandem
Drum brakes 410 mm (410 x 200)
Friction area: 3220 cm²

or

Disc brakes allround
Electronic braking system (EBS)
Brake Assist System (BAS)

ESP with OFF ROAD MODE available as option

AXLES

Position	Description
Front	5890/D OFF - Axle drop: 72 mm
Front	5890/T OFF - Assale con Drop di 72 mm
Rear	453291/2D - Tandem H.R. (Drum brake 2D)
Rear	453291_ADB - Tandem Hub Reduction (Disc Brakes)

SUSPENSIONS

Front parabolic suspension (semi-elliptic option):
Standard capacity: 8.000 kg (options for 8.500 kg and 9.000 kg)

Rear parabolic suspension STD (semi-elliptic option):
Standard capacity: 26.000 kg

BATTERY

Electrics

Voltage V	24
Alternator power V/A	28 / 90
Starter power kW	5.5
No. of batteries	2
Batteries capacity V/Ah	12 / 170

FUEL TANK 290 L

Fuelling

Capacity (l.)	290
Material	Aluminium

390L FUEL TANK

Fuelling

Capacity (l.)	390
Material	Aluminium

60L UREA TANK

Adblue tank

Capacity (l.)	60
Material	Plastic

MODEL COMPONENTS

MISCELLANEOUS

THE AVAILABILITY OF THE FOLLOWING OPTIONS DEPENDS ON VERSIONS AND MARKETS :

SAFETY :

TPMS (on cluster): Tyre Pressure Monitoring System is an electronic system which monitors the air pressure inside a tyre and provides information on faults in real time to the driver. In addition to improving vehicle safety, **TPMS** helps the driver plan tyre maintenance and contributes to reducing fuel consumption.

ESP: Electronic Stability Program (ESP).

The **ESP** system acts in skidding phase, by adjusting the engine power and braking on individual wheels with different intensities so as to stabilise the position of the vehicle. It is effective both in case of sudden deviations from the trajectory and in correcting situations of oversteer or understeer, which may occur in case of incorrectly approaching a bend.

LDWS: Lane Departure Warning System

(LDWS). The Lane Departure Warning System beeps when the vehicle strays from the lines that mark the driving lane without the indicators being activated. The system is very effective in preventing accidents due to distraction or sleepiness.

FUEL CONSUMPTION OPTIMIZATION:

ECOSWITCH: Designed to reduce fuel consumption, **ECOSWITCH** is an important aid for the driver. It activates the "iEco program" in order to optimise gear shifting strategy and performance according to actual vehicle weight, assuring the best productivity under any operating condition.

ECO ROLL: On all type of incline (also on moderate one), the eco-roll function serves to open the driveline and retain the kinetic energy of the vehicle for longer or to slightly increase it by reducing the engine-drag torque that affects the impellers. If the vehicle subsequently slows down, the engine must increase the injected fuel quantity at a later point. Driver actions during an active rolling function such as accelerator pedal, brake actuation, changing to manual, or speed range selector actuation lead to the termination of the rolling function and the closing of the driveline. Depending upon the speed range, the last gear before the rolling phase can be engaged or a new gear can be calculated and engaged when the rolling function is terminated.

ECO ROLL works in the range (50km/h ; 92km/h) and is independent from Cruise Control setting.

GPS-PREDICTIVE DRIVING (OPT Code 78878)

GPS-predictive driving is the driving strategy implemented in TraXon with predictive functionality to determine the optimal gear early for any driving situation, according to the electronic horizon information acquired via GPS by a provider and made available on the CAN bus. The electronic horizon acquires the current location of the vehicle via GPS and determines the route from topographical street maps (uphill gradient, curves, max permissible speed). GPS-predictive driving is used to improve the gear shifting and Eco-rolling strategy.

DRIVEABILITY :

ROCKING MODE (OPT Code 78507) TRAXON provides a Rocking function to have the clutch reating directly to accelerator pedal movements for rocking the vehicle out of a depression in the terrain in low grip conditions. When the Rocking mode is activated, it is possible to disengage the clutch immediately by releasing the accelerator pedal, roll back the vehicle and engage the clutch immediately again by depressing the accelerator pedal. The HMI provided for the Rocking mode includes: a dedicated switch to let the driver activate / deactivate the Rocking mode. A specific indication on the Instrument Cluster to inform when the Rocking function is active ("ROCK" indication in the transmission modes area).

OFF-ROAD MODE is an high mobility function with which the gearshifting logic allows higher rpms before shifting to faster gears, thus providing higher engine power and torque.

CREEPING MODE is an high mobility function with which the vehicle moves forward at minimum speed, simply by releasing the service brake pedal, useful for precise maneuvering operations at low speed (active via Quick Menu).



IVECO

AD380T43 H