

MOBILE WORKSHOP FOR TOYOTA LANDCRUISER HZJ79

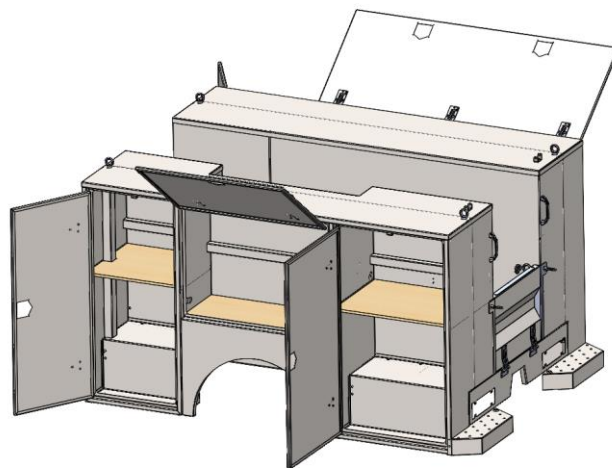

1. BODY DESCRIPTION:

APPROX. DIMENSIONS:

- External Length: 2357 mm
- External Width: 1855mm
- External Height: 1107 mm

- The Body mobile workshop module is manufactured with a tube steel structure and high quality steel thickness 1,5 mm and 2 mm.
- The body will be delivery in KIT, ready to be assembled on chassis by customer

BODY CONFIGURATION

- 3 storage cabinets on each side of the vehicle
- Each storage cabinet with door and INOX locks for each door
- Rear tail gate for access to the platform
- Anti slip floor on platform
- Electric installation for rear lights
- 2 units emergency lights mounted on the roof, on front part.
- 2 units working lights on rear part
- 2 units power output Schuko 230V

EQUIPMENT INCLUDED:

- HONDA 6 kVA Power Generator: 6,5kW1; 12V, 14l - REF: *DHY8500LEK*
 - Air Compressor 2 HP. 25 L-230V/50Hz. – dimensions 570x255x590. Weight 24kg.
 - Air Hose Reel
 - Electric Cable Hose Reel
 - Grinder
 - Column Drill – electric drill
 - Vice
 - Inverter Welding Equipment
 - Mechanical Tool Box. 90 pieces
 - Fire extinguisher – 2 Kg.
 - Manual greasing and lubrication equipment
-

PAINTING PROCESS

During the metalwork process all the overlapped point are covered with an epoxy primer. All the steel elements will receive a sandblasting treatment (SA 2 ½ acc.to SIS standard).

Painting in RAL colour white

ELS will provide full support, assistance and documentation for the assembly process, spare parts, and maintenance and after sale.

OPERATION MANUAL / SPARE PARTS

One set will be supplied incl. operating and maintenance instructions, diagrams and drawings, spare parts catalogue literature in **ENGLISH** language.

PRODUCTION

It will be executed under the established quality control system ISO 9001.